

# Richter Lined Check Valves

CV, BC, SR, GR, RV, PRS

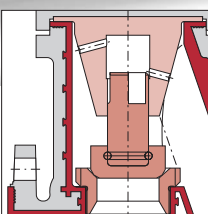

Lining PFA, PTFE,  
PFA-L antistatic  
Liquids, vapours and gases  
Vertical, inclined or  
horizontal installation



## Richter check valves

They prevent from back-flow of liquids, gases and vapours in pipelines.

### They are installed

- e.g. in the discharge line, directly downstream of the pump, to prevent the siphoning of the pump or pump rotation in the opposite direction as a result of back-flowing liquids
- when vessels have to be vented/aerated within approximate setting ranges.

### Richter check valves are designed

- for media where stainless steel does not offer lasting corrosion resistance
- as an alternative to valves made of exotic expensive metals (Hastelloy®, Monel®, tantalum etc.)
- for pure and slightly solids-laden media
- for metal-reactive media, e.g. H<sub>2</sub>O<sub>2</sub>
- for pure media where good cleaning possibilities and anti-adhesive surfaces are important.

### Operating range:

Depending on design and material

- from -60 to +180 °C (-75 to 360 °F) with EN-JS 1049
- from -29 to +180 °C (-20 to 360 °F) with ASTM A395
- from vacuum up to 16 bar (235 psi)

### Installation and connecting dimensions

- **ISO/DIN:** face-to-face lengths DIN EN 588-1, basic series 1 (ISO 5752, basic series 1).  
Flange connecting dimensions: DIN EN 1092-2, shape B (ISO 7005-2, type B), on request drilled to ANSI 150
- Face-to-face lengths Peabody-Dore (BC/BCV series)
- **ANSI/ISA-** 75.08.01 Cl. 150 with flanges acc. to ASME B16.5 Cl. 150 raised face (series GR)
- **ANSI/ISA-** 75.08.01 Cl. 300 with flanges acc. to ASME B16.5 Cl. 300 raised face for series GR 1", 1½", 2" on request.

### Series selection

The operating conditions are so varied that the Richter range contains a large number of check valves:

Series selection	CV	CVV	BC	BCV	SR	SR-B	SRV	SRV-B	SRZ-V	GR	RV	PRS
ISO face-to-face	•	•			•	•	•	•	•	•	•	•
Peabody-Dore/ASME face-to-face			•	•						•		
Gas-tight in seat						•		•	•	•	•	•
Seat or seat seal replaceable						•		•	•	•	•	•
Horizontal installation	•	•	•	•	•	•	•	•		•		•
Vertical installation	•	•	•	•	•	•	•	•	•		•	•
Inclined installation*	•	•	•	•	•	•	•	•				•
Operating pressure > 3 bar (43.5 psi)	•		•		•	•			•	•	•	•
Vacuum-tight	•	•	•	•	•	•	•	•	•	•	•	•
Operating temperature > 100 °C (210 °F)	•		•		•	•			•	•	•	•
Operating temperature < -10 °C (-15 °F)	•	•	•	•	•		•			•	•	•
Integrated sight glass function					•	•	•	•	•			
Top-entry design										•		

\* Guidance in centre under ball

### ① Lining virgin pure PFA or PTFE

- Suitable for corrosive, hazardous, pure, hot and highly permeating media
- Thick-walled, high permeation resistance
- Vacuum-resistant anchoring
- Lining optionally antistatic available

### ② Shell made of ductile cast iron

**EN-JS 1049 (ASTM A395)** absorbs system and pipe forces

### ③ Shut-off elements: solid and hollow

- balls as well as solid and hollow plugs made of PTFE. For special cases made of stainless steel, Hastelloy® etc.
- Gas-tight sealing: series SR-B, SRV-B and SRZ-V optionally with soft-sealing fluorocautchouc seat sealing.
- Series GR and RV generally gas-tight sealing.

### ④ Horizontal, inclined or vertical installation

### ⑤ External corrosion protection

Epoxy coating, nuts and bolts of stainless steel.

### ⑥ Identification DIN EN 19, ASME B16.34

### ⑦ PED Pressure Equipment Directive

The valves are suitable for liquids, vapours, gases of group 1.

## CV, CVV (ISO) and BC, BCV (ASME) series

Installation: horizontal, inclined, vertical pipe

- CV, BC series: with solid ball
- CVV, BCV series: with hollow ball
- Tightness: DIN EN 12266-1, leakage rate D, test medium gas

These ball check valves have a hydraulically optimised design. The lining thickness of 4 to 5 mm offers very high permeation resistance.

The **CV and BC series with a solid ball** seal against a **falling or back-flowing** liquid.

The **CVV and BCV versions with a hollow ball** can also be used for low opening differential pressures. If the installation position is reversed, CVV and BCV can also work as **vacuum check and aeration valves**. When installed vertically, the ball then floats on the rising liquid and seals upwards into the seat.

When installed horizontally, a minimum differential pressure of 1 bar (14.5 psi) – with a hollow ball 0.5 bar (7.25 psi) – is necessary so that the ball is pressed into the seat.

## GR series

Installation: horizontal pipe

- Only with solid plug
- Tightness: gas-tight to DIN EN 12266-1, leakage rate A, test medium gas

GR check valves are designed as plug valves and intended for horizontal installation. Seat and plug are exchangeable.

Thanks to the top-entry design, the valve can be opened from the top and serviced.

Lining thickness: 5-6 mm, DN 15+20 (1/2 + 3/4") 3.5-4 mm.

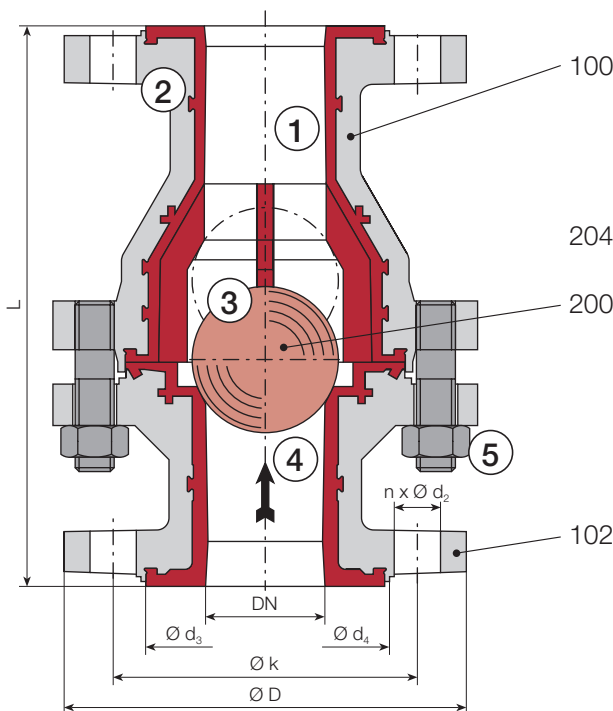

Fig.: CV, BC series, vertical installation, sealing against falling liquid.

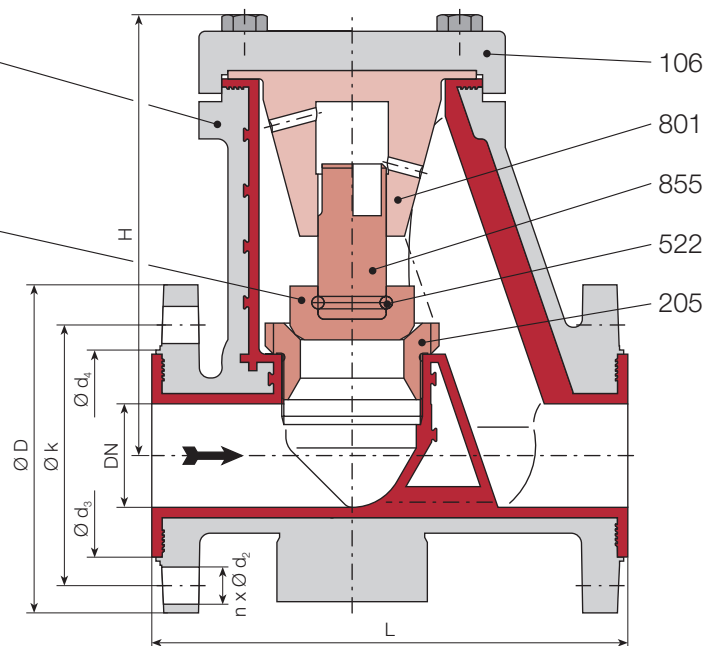

Fig.: GR series, horizontal installation, sealing against back-flowing liquids, vapours, gases

## SR, SRV, SR-B, SRV-B and SRZ-V series with integrated sight glass

Installation: horizontal, inclined, vertical (SRZ-V, only vertical) pipe

- SR series with solid ball
- SRV series with hollow ball
- SR-B series with solid ball and soft-sealing seat
- SRV-B with hollow ball and soft-sealing seat
- SRZ-V series with hollow plug and soft-sealing seat

Tightness:

- SR and SRV: DIN EN 12266-1, leakage rate D, test medium gas
- SR-B, SRV-B, SRZ-V: gas-tight to DIN EN 12266-1, leakage rate A, test medium gas

These series make it possible to observe the function of the check valve through thick sight glasses made of borosilicate glass to DIN 7080.

The functions of a straight-through sight glass are fulfilled.

The **solid ball SR and SR-B versions** seal against a **falling or back-flowing liquid**.

The SRV and SRV-B versions with **hollow balls** can also be used for **low opening differential pressures**.

With reversed installation position, SRV and SRV-B also function as **vacuum check and aeration valves**. The ball then floats on the rising liquid and seals upwards into the seat.

When installed horizontally, a minimum differential pressure of 1 bar (14.5 psi) – with a hollow ball 0.5 bar (7.25 psi) – is necessary to press the ball into the seat.

The **hollow plug version SRZ-V** functions in the same way as SRV and SRV-B but for a **much larger pressure/temperature range**, see diagram on page 5.

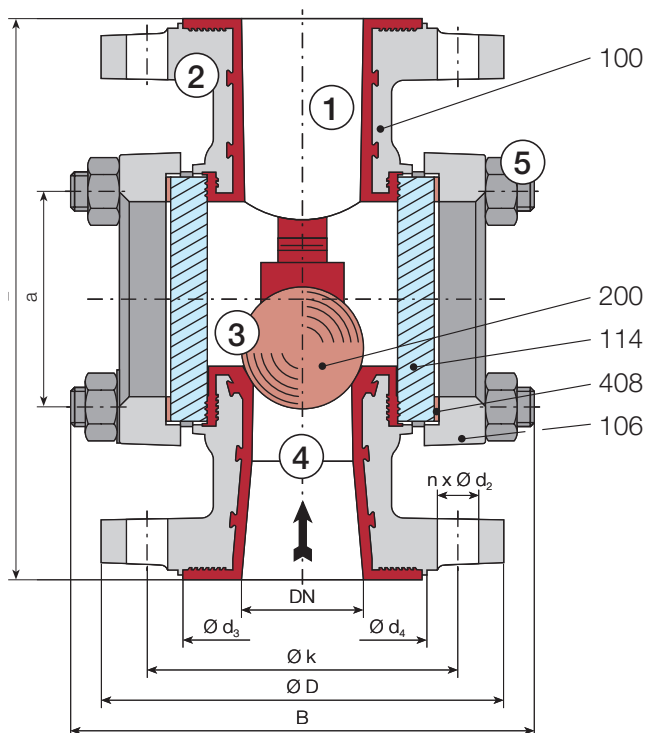

Fig.: SR series, vertical installation, sealing against falling liquid, without seat seal

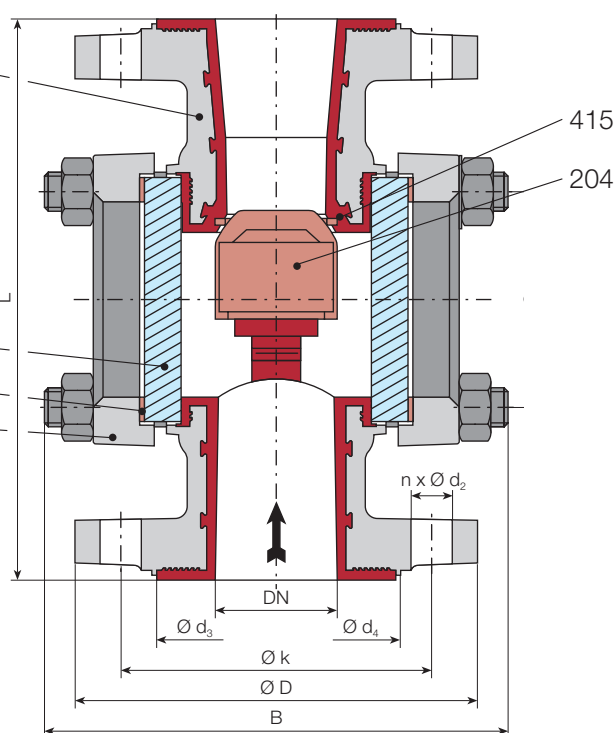

Fig.: SRZ-V series, vertical installation, sealing against rising liquids, with hollow plug and soft-sealing seat seal

## Materials, dimensions, weights, pressure/temperature diagram

### Components and materials

Item	Designation	Materials
100 102	Body and body end piece	Shell Ductile cast iron EN-JS 1049 (ASTM A395)
		Lining see separate table
106	Cover	Ductile cast iron EN-JS 1049 (ASTM A395), GR series optionally GS-C25 (1.0619)
114	Sight glass pane	Borosilicate glass (e.g. Maxos®)
200	Ball	PTFE <sup>1)</sup> , optionally stainless steel, Hastelloy® etc.
204	Plug	Modified PTFE <sup>1)</sup>
205	Seat	Modified PTFE <sup>1)</sup>
408	Flat gasket	Aramide
415	Seat seal (optional for SR-B, SRV-B, SRZ-V)	FFKM
522	Round cord	PTFE
801	Guide	Modified PTFE <sup>1)</sup>
855	Stem	Modified PTFE <sup>1)</sup>
w/o No.	Screws, nuts	Stainless steel

<sup>1)</sup> for lining PFA conductive: PTFE/carbon

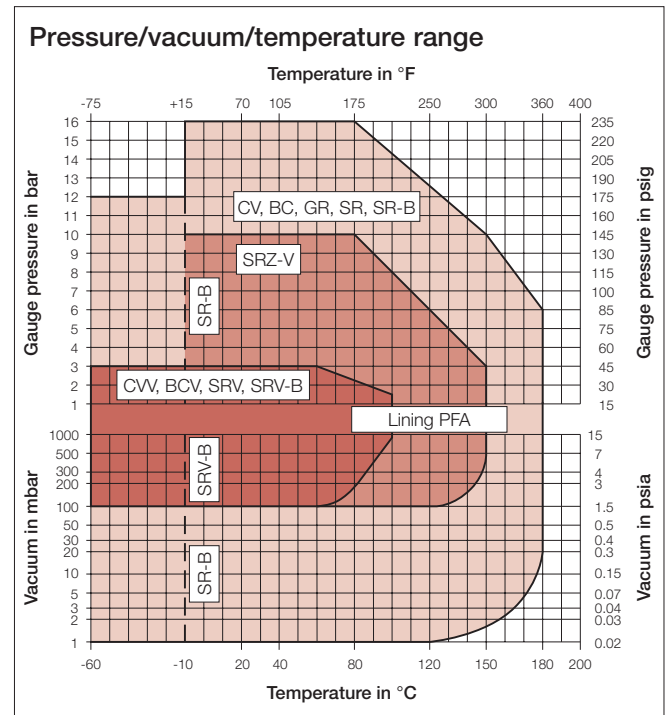

### Installation and connecting dimensions:

**CV, CVV, GR, SR, SR-B, SRV, SRV-B, SRZ-V series to ISO 7005-2 PN 16**

DN <sup>1)</sup> (mm)	DN <sup>1)</sup> (inch)	L	D	k	d <sub>3</sub>	d <sub>4</sub>	nxd <sub>2</sub>	a
15	1/2"	130	95	65	41	45	4x14	-
20	3/4"	150	105	75	54	58	4x14	-
25	1"	160	115	85	64	68	4x14	48
40	1 1/2"	200	150	110	84	88	4x19	65
50	2"	230	165	125	98	102	4x19	80
65	2 1/2"	290	285	145	118	122	4x19	80
80	3"	310	200	160	134	138	8x19	100
100	4"	350	220	180	154	158	8x19	125
150*	6"	394	279	241.5	-	-	8x22	-

\* DN 150 (6") from BC/BCV series, face-to-face not to ISO/DIN, 100 mm (4") bore

### Installation and connecting dimensions:

**BC, BCV, GR series to ASME Cl. 150 (ISO 7005-2 PN20) and Peabody-Dore.**

Series GR to ASME Cl. 300 on request

DN (mm)	DN (inch)	L		D		k	d <sub>3</sub>	d <sub>4</sub> <sup>6)</sup>	nxd <sub>2</sub>	H
		BC, BCV	GR	BC, BCV	GR	Series	BC, BCV, GR	BC, BCV, GR	BC, BCV, GR	GR
15	1/2"	130 <sup>1)</sup>	130	95	105	60.5	50	54	2)	112
20	3/4"	150 <sup>1)</sup>	150	105	105	70.0	50	54	4x16	112
25	1"	152	184	108	110	79.5	51 <sup>3)</sup>	58 <sup>4)</sup>	4x16	156
40	1 1/2"	178	222	127	130	98.5	73	77	4x16	197
50	2"	178	254	152	155	120.5	92	96	4x18	205
80	3"	203	298	190	190	152.5	127	130	4x18	313
100	4"	267	353	228	230	190.5	157	160	8x18	327
150	6" <sup>5)</sup>	394	-	279	-	241.5	-	-	8x22	-

<sup>1)</sup> not to Peabody-Dore

<sup>2)</sup> tapped bore 4x1/2"-13 UNC

<sup>3)</sup> GR series: 58 mm

<sup>4)</sup> plastic sealing strip

<sup>5)</sup> passage 4"

<sup>6)</sup> BC/BCV without metallic sealing strip

### Nominal sizes, lining materials, k<sub>v</sub> (Cv) values and weights

DN (mm)	DIN/ISO series								
	CV, CVV series			SR, SR-B, SRV SRV-B, SRZ-V <sup>3)</sup> series			GR series		
	Lining <sup>1)</sup>	k <sub>v</sub> <sup>2)</sup>	kg	Lining <sup>1)</sup>	k <sub>v</sub> <sup>2)</sup>	kg	Lining <sup>1)</sup>	k <sub>v</sub> <sup>2)</sup>	kg
15	PFA PFA-L	8.5	3.2	-	-	-	PFA PFA-L	3.5	5.2
20	PFA	16	3.8	-	-	-	PFA PFA-L	3.5	5.5
25	PFA PFA-L	27	5.2	PFA PFA-L	15 (SRZ-V: 10)	6.2	PFA PFA-L	13	9.3
40	PFA PFA-L	97	9.1	PFA PFA-L	35	8.9	PFA PFA-L	28	13.2
50	PFA PFA-L	122	12.6	PFA PFA-L	50 (SRZ-V: 35)	14.5	PFA PFA-L	40	17
65	PFA	57	15	-	-	-	PFA PFA-L	46	18
80	PFA PFA-L	300	25	PFA PFA-L	125	25	PFA	110	38
100	PFA PFA-L	410	40	PFA PFA-L	170	37	PFA	135	43
150	PFA PFA-L from BC / BCV series	360	47	-	-	-	-	-	-

<sup>1)</sup> PFA-L = PFA conductive (antistatic)

<sup>2)</sup> k<sub>v</sub> in m<sup>3</sup>/h (water 20 °C, 68 °F). Conversion to Cv = k<sub>v</sub> x 1.165 (US gpm) or Cv = k<sub>v</sub> x 0.971 (IMPgpm)

<sup>3)</sup> SRZ-V: only DN 25+50 (1 + 2")

DN (inch)	ASME (ANSI) series					
	BC, BCV series			GR series		
	Lining <sup>1)</sup>	k <sub>v</sub> <sup>2)</sup>	kg	Lining <sup>1)</sup>	k <sub>v</sub> <sup>2)</sup>	kg
1/2"	PFA PFA-L	7	2.8	PFA PFA-L	3.5	5.2
3/4"	PFA PFA-L	11	3	PFA PFA-L	3.5	5.5
1"	PFA PFA-L	22	3.7	PFA PFA-L	13	10
1 1/2"	PFA PFA-L	63	6.3	PFA PFA-L	28	14.5
2"	PFA PFA-L	92	8.4	PFA PFA-L	40	19
2 1/2"	-	-	-	-	-	-
3"	PFA	200	22	PFA	110	37
4"	PFA PFA-L	360	35	PFA	135	41
6"	PFA PFA-L	360	47	-	-	-

## Other Richter check valves

### RV series

- Installation: vertical pipe
- -60 to 180 °C (-75 to 360 °F)
- Vacuum 100 mbar to 10 bar (1,45 to 145 psi)
- DN 150 (6"), face-to-face 240 mm,  $k_v$ -value 400 m<sup>3</sup>/h (1760 US gpm) and DN 200 (8"), 280 mm, 500 m<sup>3</sup>/h (2200 US gpm)
- Gas-tight to DIN EN 12266-1, leakage rate A, test medium gas
- Body: ductile cast iron EN-JS 1049 (ASTM A395), lining PTFE
- Seat and plug exchangeable
- Flanges ISO 7005-2 PN16, on request drilled to ASME Cl.150 (ISO 7005-2 PN20)

Details on pressure/temperature range, materials, dimensions, etc. on request

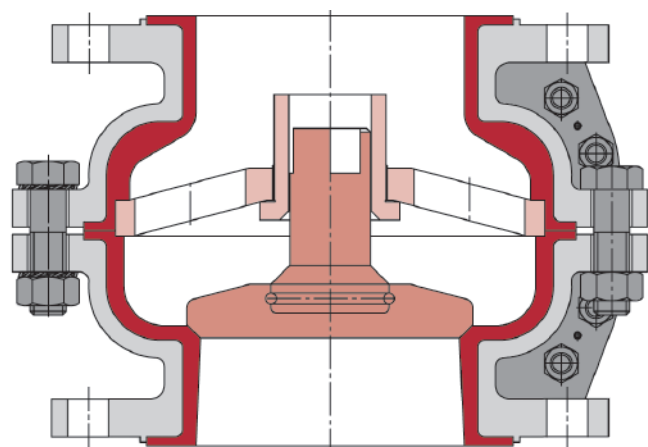

RV series

### PRS series

The PRS overflow valve can also be used at low differential pressures to prevent the back-flow of gases, vapours and liquids. The seat/plug combination pre-tensioned with cup springs seals reliably.

- Installation: horizontal and vertical pipe
- -60 to 50 °C (-75 to 120 °F)
- Vacuum to 16 bar (235 psi)
- DN 25 (1"), face-to-face 160 mm
- Gas-tight to DIN EN 12266-1, leakage rate A, test medium gas
- Body: ductile cast iron EN-JS 1049 (ASTM A395), lining PTFE
- Plug, guide etc. exchangeable
- Flanges ISO 7005-2 PN16, on request drilled to ASME Cl. 150 (ISO 7005-2 PN20)

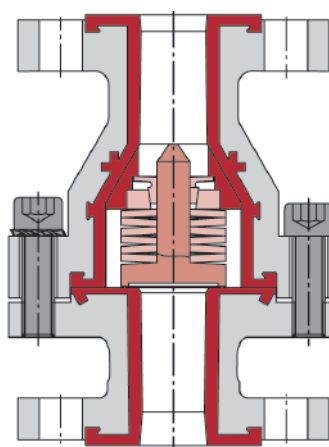

PRS series

Richter = TM Richter Chemie-Technik GmbH  
MAXOS® = TM Schott AG  
Hastelloy® = TM of Haynes International  
Monel® = TM of Special Metals Corp.

Distributed by:



**GAA-Lobex Sp. z o.o.**  
ul Traugutta 39  
37-500 Jarosław / Poland

tel.: 16 621 08 91  
lobex@gaa.com.pl  
[www.gaa.com.pl](http://www.gaa.com.pl)



**Richter Chemie-Technik GmbH**  
Otto-Schott-Str. 2, D-47906 Kempen, Germany  
Tel. +49(0) 21 52/146-0, Fax +49(0) 21 52/146-190  
[www.richter-ct.com](http://www.richter-ct.com), [richter-info@idexcorp.com](mailto:richter-info@idexcorp.com)