



400-3300 GPM Up to 300 PSI



SERIES 323F

IMO SERIES 323F pumps are positive displacement, double-ended rotary, screw-type pumps designed and engineered for excellent suction capability over a wide range of fluid viscosities. Flow rates (400 to 3300 GPM) are proportional to rotating speed when the pump is operated within the recommended pressure range. The self-priming design permits both evacuation of air filled inlet lines and repriming if suction is lost.

The unique IMO design—only three moving parts—is the key to the SERIES 323F pump performance. A precision bored housing encases the driven screw (power rotor) and intermeshing sealing screws (idler rotors). The accurately machined idler rotors conform perfectly to the threads of the power rotor and to the housing bores, confining the fluid in a succession of closures or cavities. As the screws rotate, the fluid is moved axially from the inlet port to the outlet port in a continuous, uniform flow. This uniform axial flow results in a minimum of fluid pulsation and extremely quiet operation.

The rotating idler rotors generate a hydrodynamic film of fluid which supports the idlers in the housing

bore and prohibits wearing contact. The strength of this film is based on fluid viscosity, pump pressure and speed. As pressure requirements increase, the hydrodynamic film can be strengthened by increasing viscosity or speed. Both the flow rate and pressure capability of the IMO pump increase with speed.

The symmetrical arrangement of the rotors (screws) eliminates the need for bearings to absorb radial loads. Axial loads are balanced hydraulically within the pump.

SERIES 323F pumps are offered in four rotor sizes for foot mounted configurations. A variety of construction materials are available to meet operating conditions and job specifications. Complete pump/driver assemblies can be provided as required.

The simple design of the SERIES 323F pump permits fast, easy installation, low maintenance, and ease of repair. All wearing parts are completely replaceable. Periodic inspections can be made without removing the pump, and routine maintenance can be performed without disturbing system piping.

Applications

SERIES 323F pumps are designed to meet the requirements for a wide variety of applications including highly viscous fluids, hydraulic, lubricating, residual fuel and crude oils. These units have been widely utilized in refineries, chemical and petrochemical plants, lubricating systems and high flow pump boosting stations—wherever high performance and reliability in a rugged design are required.

Typical applications are:

Transfer of polymers, chemicals, glycols, vegetable

oils, paraffins, molasses, grease, paint, asphalt and other highly viscous and/or shear sensitive type fluids in pipelines and process systems.

Loading and Unloading of lube, fuel, bunker, crude, waste and similar type oils in refineries, factories, storage and settling tanks.

Lubrication of diesel engines, gas turbines, steam turbines, compressors, transmission gears, large centrifugal pumps, and other rotating machinery.

Series 323F Standard Specifications and Features

CASING	High tensile gray cast iron. Optional steel casing available. Steam jacketing available on steel cased pumps (maximum 150 psig steam).	
ROTOR HOUSINGS	Cast gray iron.	
POWER ROTOR	Alloy steel.	
IDLER ROTORS	Pearlitic Nodular Iron.	
GASKETS	Cellulose and non-asbestos fiber.	
SHAFT SEAL	<p>Type P: Alternate rows of hard and soft square molded packing. For applications requiring packing.</p> <p>Type B: Buna N bellows mechanical seal with NI resist seat. For clean applications requiring a mechanical seal.</p> <p>Type H: Positive drive mechanical seal with iron seat. For higher viscosity and/or temperature and residual and crude oil applications.</p>	
DISCHARGE PRESSURE	300 PSIG Maximum. <i>40 psi minimum when viscosity \geq 100 SSU or 25 psi when $<$ 100 SSU.</i>	
INLET PRESSURE	25 PSIG Maximum.	
SPEED	1200 RPM Maximum.	
VISCOSITY	<p>Type P: 100–25,000 SSU. Recommended for residual and crude oils.</p> <p>Type B: 8.0 cst (50 SSU)–3000 SSU. Recommended for clean oils.</p> <p>Type H: 8.0 cst (50 SSU)–20,000 SSU. Recommended for viscosities over 3000 SSU and all residual crude oils.</p> <p>All Types: consult IMO for lower or higher viscosities.</p>	
TEMPERATURE	<p>Type P: 0–250°F Type H: 0–250°F</p> <p>Type B: 0–180°F</p> <p>Designs available to 500°F. Consult IMO.</p>	
DRIVE	Direct only.	
ROTATION	Clockwise facing pump shaft.	
MOUNTING	Horizontal Foot Mount. Optional vertical mounting available for certain applications. Consult IMO.	
FILTRATION	Inlet strainers are required to keep contaminants and abrasives out of pump, but they must be selected with consultation with strainer vendor to prevent pump starvation. Normally, 60 mesh for light oils and 1/8"–3/16" openings for heavy oils are recommended.	
ACCESSORIES	Steel bedplates and completely mounted pump/driver assemblies.	
WR ² (Approximate)	<u>Rotor Size</u>	<u>WR²</u>
	550 J & 550	260 lb-in ²
	630 M	990 lb-in ²
	800 J	2276 lb-in ²

Typical 323F Assemblies

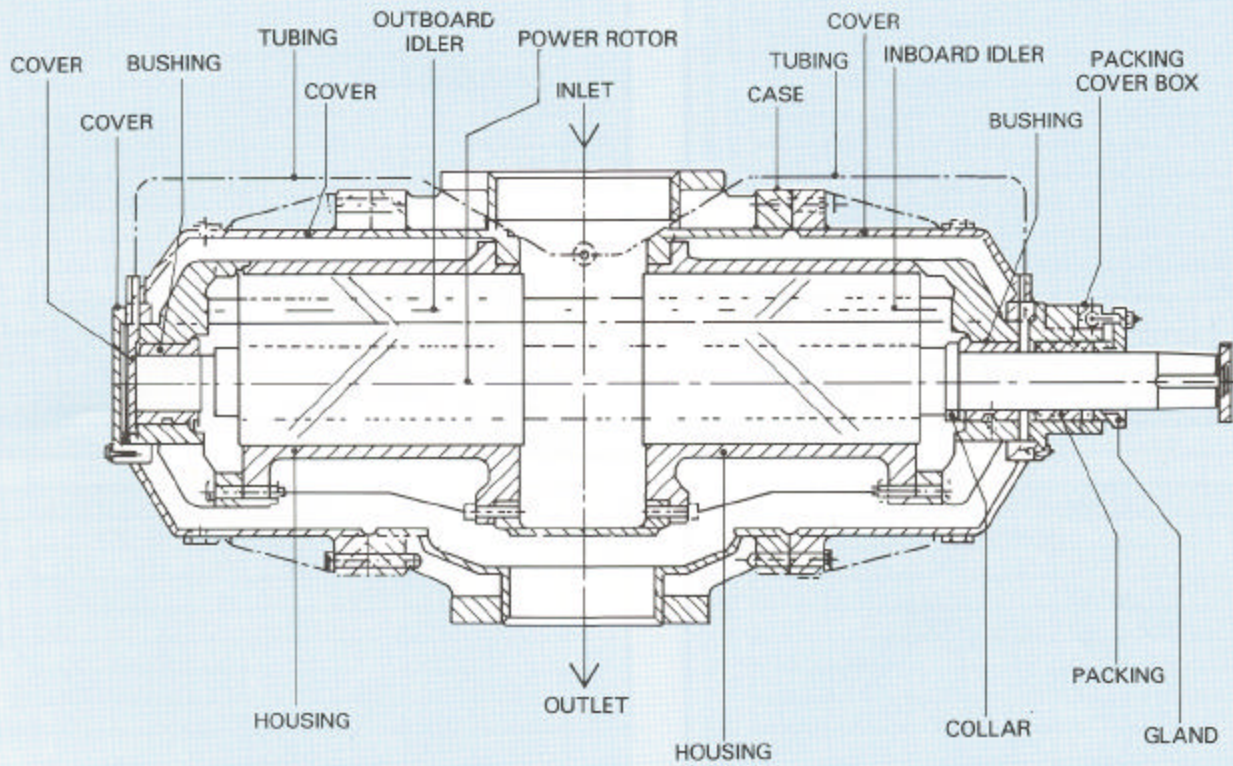

Typical for models with Shaft Packing

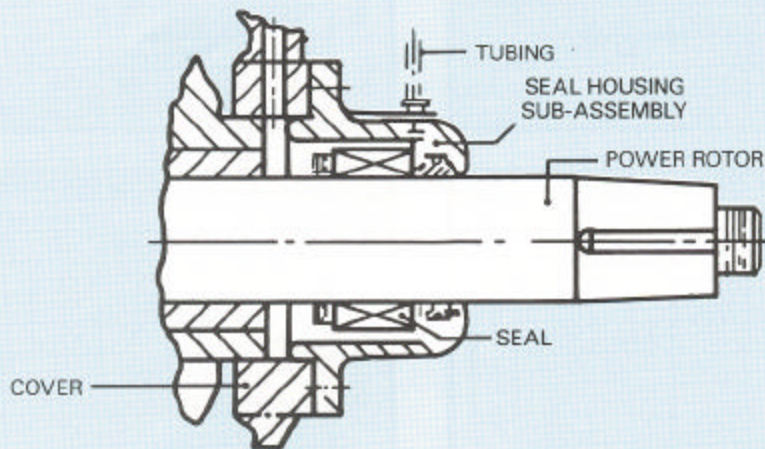

Typical Shaft End for models with Mechanical Seals

Series 323F Performance Data (All Fluids)

323F Rotor Size 550J								
Speed 1150 RPM								
Viscosity	SSU	Differential Pressure—PSI						Net Inlet Pressure Required (PSIA)
		50	100	150	200	250	300	
USGPM	50	977	925	880	—	—	—	
	100	1016	977	946	925	903	880	
	200	1043	1015	996	977	962	946	
	500	1067	1050	1037	1025	1016	1007	
	1000	1080	1067	1059	1050	1044	1037	
	3000	1091	1083	1080	1073	1069	1066	
	5000	1096	1091	1089	1086	1082	1077	
BHP	200	40	73	105	137	170	202	5.9
	500	46	79	111	143	176	208	6.4
	1000	53	85	119	150	183	214	6.7
	3000	75	108	140	172	204	237	9.0
	5000	89	122	156	187	220	251	12.2
	10000	119	151	187	216	252	280	19.0
	12000	133	166	198	230	263	295	22.0
Speed 960 RPM								
Viscosity	SSU	Differential Pressure—PSI						Net Inlet Pressure Required (PSIA)
		50	100	150	200	250	300	
USGPM	50	791	736	—	—	—	—	
	100	830	791	761	736	—	—	
	200	858	830	809	791	775	761	
	500	882	865	851	840	830	821	
	1000	895	893	873	865	858	852	
	3000	908	900	895	890	886	883	
	5000	911	906	902	898	895	892	
BHP	200	33	60	87	114	141	168	5.3
	500	37	64	91	118	145	172	5.5
	1000	42	69	96	123	150	177	5.8
	3000	57	84	111	138	165	192	7.0
	5000	68	95	122	149	176	203	8.4
	10000	90	117	144	171	198	225	12.5
	20000	124	151	178	205	232	259	20.0
25000	138	165	192	219	246	273	24.0	
Speed 870 RPM								
Viscosity	SSU	Differential Pressure—PSI						Net Inlet Pressure Required (PSIA)
		50	100	150	200	250	300	
USGPM	50	707	655	—	—	—	—	
	100	746	707	676	655	—	—	
	200	773	745	726	707	692	676	
	500	797	780	767	755	746	737	
	1000	810	797	789	780	774	767	
	3000	821	814	810	804	800	796	
	5000	826	821	819	816	812	807	
BHP	200	29	54	78	103	127	152	4.9
	500	33	57	81	106	130	155	5.2
	1000	37	61	86	110	135	159	5.4
	3000	49	74	98	123	147	171	6.3
	5000	58	82	107	131	156	185	7.3
	10000	75	99	125	148	174	197	9.8
	20000	101	126	153	175	202	224	15.0
25000	116	141	165	190	214	238	17.5	

323F Rotor Size 550J								
Speed 720 RPM								
Viscosity	SSU	Differential Pressure—PSI						Net Inlet Pressure Required (PSIA)
		50	100	150	200	250	300	
USGPM	50	560	505	—	—	—	—	
	100	599	560	530	—	—	—	
	200	627	599	578	560	544	530	
	500	651	634	620	609	599	590	
	1000	664	651	642	634	627	620	
	3000	676	669	664	659	655	651	
	5000	680	675	670	667	664	661	
BHP	200	23	44	64	84	104	125	4.7
	500	26	46	66	87	107	127	4.8
	1000	29	49	69	90	110	130	4.9
	3000	37	57	78	98	118	138	5.5
	5000	44	64	84	104	125	145	5.9
	10000	56	76	97	117	137	157	7.5
	25000	83	104	124	144	164	185	12.2
Speed 690 RPM								
Viscosity	SSU	Differential Pressure—PSI						Net Inlet Pressure Required (PSIA)
		50	100	150	200	250	300	
USGPM	50	522	476	—	—	—	—	
	100	571	522	502	—	—	—	
	200	598	570	551	532	517	501	
	500	622	605	593	580	571	562	
	1000	635	622	614	605	599	592	
	3000	647	640	635	630	626	622	
	5000	651	646	643	641	637	632	
BHP	200	22	42	61	81	100	119	4.5
	500	25	44	63	83	102	122	4.6
	1000	27	46	66	85	105	124	4.8
	3000	35	54	74	93	113	132	5.2
	5000	40	59	80	98	118	137	5.8
	10000	51	70	91	109	130	147	7.1
	20000	68	88	109	126	147	165	10.3
25000	77	97	116	136	155	174	11.3	
Speed 570 RPM								
Viscosity	SSU	Differential Pressure—PSI						Net Inlet Pressure Required (PSIA)
		50	100	150	200	250	300	
USGPM	50	417	360	—	—	—	—	
	100	456	417	386	—	—	—	
	200	483	455	436	417	401	—	
	500	507	490	477	465	456	447	
	1000	520	507	499	490	484	477	
	3000	532	525	520	515	511	507	
	5000	536	531	529	526	522	517	
BHP	200	18	34	50	66	82	98	4.3
	500	19	35	52	67	84	99	4.4
	1000	21	37	53	69	85	101	4.5
	3000	27	43	59	75	91	107	4.8
	5000	30	46	63	78	95	110	5.2
	10000	38	54	71	86	103	118	5.9
	20000	49	65	83	97	115	129	7.3
25000	56	72	88	104	120	136	9.2	

323F Rotor Size 550								
Speed 1150 RPM								
Viscosity SSU	Differential Pressure—PSI						Net Inlet Pressure Required (PSIA)	
	50	100	150	200	250	300		
USGPM	50	1347	1292	1246	—	—	—	
	100	1386	1347	1316	1292	1266	1246	
	200	1413	1373	1360	1347	1331	1316	
	500	1438	1422	1407	1395	1386	1377	
	1000	1450	1438	1429	1421	1414	1407	
	3000	1460	1453	1450	1443	1439	1435	
	5000	1467	1461	1457	1453	1450	1447	
BHP	200	53	96	140	182	226	269	8.3
	500	61	105	148	191	234	278	9.2
	1000	71	114	158	200	244	287	10.3
	3000	100	143	186	229	272	315	17.0
	5000	118	162	207	248	293	334	25.0
Speed 960 RPM								
Viscosity SSU	Differential Pressure—PSI						Net Inlet Pressure Required (PSIA)	
	50	100	150	200	250	300		
USGPM	50	1100	1044	—	—	—	—	
	100	1139	1100	1070	1044	—	—	
	200	1166	1139	1117	1100	1084	1070	
	500	1191	1173	1160	1149	1139	1130	
	1000	1203	1191	1181	1173	1166	1160	
	3000	1216	1209	1203	1199	1195	1191	
	5000	1220	1214	1210	1206	1203	1200	
BHP	200	43	79	115	151	187	223	6.6
	500	49	85	121	157	193	229	7.1
	1000	56	92	128	164	200	236	7.8
	3000	76	112	148	184	219	255	10.8
	5000	90	126	162	198	234	270	15.0
10000	119	155	191	227	263	299	26.0	
Speed 870 RPM								
Viscosity SSU	Differential Pressure—PSI						Net Inlet Pressure Required (PSIA)	
	50	100	150	200	250	300		
USGPM	50	987	932	—	—	—	—	
	100	1026	987	956	932	—	—	
	200	1053	1026	1006	987	971	956	
	500	1078	1062	1047	1035	1026	1017	
	1000	1090	1078	1069	1061	1054	1047	
	3000	1100	1093	1090	1083	1079	1075	
	5000	1107	1101	1097	1093	1090	1087	
BHP	200	38	71	104	136	169	201	5.9
	500	43	76	109	141	174	206	6.4
	1000	51	84	114	149	180	214	6.7
	3000	65	98	130	163	196	228	9.0
	5000	76	109	143	174	208	239	12.2
	10000	99	132	167	197	232	262	19.0
	12000	110	142	175	207	240	273	22.0

323F Rotor Size 550								
Speed 720 RPM								
Viscosity SSU	Differential Pressure—PSI						Net Inlet Pressure Required (PSIA)	
	50	100	150	200	250	300		
USGPM	50	791	736	—	—	—	—	
	100	830	791	761	—	—	—	
	200	858	830	809	791	776	761	
	500	883	865	852	840	830	821	
	1000	895	883	873	865	858	852	
	3000	908	900	895	890	886	883	
	5000	911	906	902	898	895	892	
BHP	200	31	58	85	112	139	166	5.3
	500	34	61	88	115	142	169	5.5
	1000	38	65	92	119	146	173	5.8
	3000	49	76	103	130	157	184	7.0
	5000	58	85	112	139	166	193	8.4
	10000	74	101	128	155	182	209	12.5
	25000	100	127	154	181	208	235	20.0
25000	110	137	164	191	218	245	24.0	
Speed 690 RPM								
Viscosity SSU	Differential Pressure—PSI						Net Inlet Pressure Required (PSIA)	
	50	100	150	200	250	300		
USGPM	50	752	697	—	—	—	—	
	100	790	752	715	—	—	—	
	200	818	791	772	752	736	721	
	500	843	825	812	800	791	782	
	1000	855	843	834	826	819	812	
	3000	869	862	855	852	848	844	
	5000	872	866	862	859	855	852	
BHP	200	29	55	81	107	133	159	5.3
	500	32	58	84	110	136	162	5.4
	1000	36	62	87	113	140	165	5.4
	3000	47	72	98	124	150	176	6.8
	5000	53	79	105	131	158	183	7.8
	10000	68	94	120	146	173	198	11.3
	25000	91	116	132	168	196	220	17.3
25000	103	128	154	180	206	232	20.0	
Speed 570 RPM								
Viscosity SSU	Differential Pressure—PSI						Net Inlet Pressure Required (PSIA)	
	50	100	150	200	250	300		
USGPM	50	600	543	—	—	—	—	
	100	639	600	569	—	—	—	
	200	666	639	619	600	584	—	
	500	691	675	660	648	639	630	
	1000	703	691	682	674	667	660	
	3000	715	708	703	698	694	690	
	5000	720	714	710	706	703	700	
BHP	200	24	45	67	87	109	130	4.9
	500	26	47	69	90	111	133	4.9
	1000	28	49	71	92	114	135	5.1
	3000	36	57	78	100	121	142	5.7
	5000	40	61	83	104	126	147	5.9
	10000	50	71	94	114	137	157	7.8
	25000	64	87	110	130	153	173	12.0
25000	74	95	117	138	159	181	13.5	

1. For conditions between listed values, interpolate between those values. For conditions not listed or off tables, contact IMO. See page 8 for an interpolation example.
2. Net Inlet Pressure Required is minimum pressure above vapor pressure at pump inlet to prevent cavitation. This assumes that the fluid is air and gas free.
3. For BHP values at viscosities below 200 SSU, use values listed for 200 SSU.

Series 323F Performance Data (All Fluids)

323F Rotor Size 630M								
Speed 1150 RPM								
Viscosity SSU	Differential Pressure—PSI						Net Inlet Pressure Required (PSIA)	
	50	100	150	200	250	300		
USGPM	50	1770	1699	1643	—	—	—	
	100	1822	1770	1731	1699	1671	1643	
	200	1858	1822	1796	1770	1750	1731	
	500	1889	1870	1850	1834	1822	1810	
	1000	1906	1889	1878	1867	1859	1850	
	3000	1920	1911	1906	1897	1892	1887	
	5000	1928	1920	1916	1911	1907	1902	
BHP	200	70	126	184	240	297	353	8.3
	500	81	137	195	251	308	364	9.2
	1000	93	150	208	263	321	377	10.3
	3000	131	188	244	301	358	414	17.0
	5000	178	212	272	325	385	438	25.0
Speed 960 RPM								
Viscosity SSU	Differential Pressure—PSI						Net Inlet Pressure Required (PSIA)	
	50	100	150	200	250	300		
USGPM	50	1446	1374	1318	—	—	—	
	100	1498	1446	1407	1374	1345	1318	
	200	1534	1498	1470	1446	1426	1407	
	500	1566	1543	1526	1511	1498	1486	
	1000	1582	1566	1554	1543	1534	1526	
	3000	1599	1590	1582	1576	1571	1566	
	5000	1604	1597	1591	1586	1582	1579	
BHP	200	57	104	152	199	246	294	6.6
	500	65	112	159	206	254	301	7.1
	1000	74	121	168	216	263	310	7.8
	3000	99	147	194	241	289	336	10.8
	5000	119	166	213	261	308	355	15.0
	10000	157	204	252	299	346	394	26.0
Speed 870 RPM								
Viscosity SSU	Differential Pressure—PSI						Net Inlet Pressure Required (PSIA)	
	50	100	150	200	250	300		
USGPM	50	1295	1224	1166	—	—	—	
	100	1347	1295	1256	1224	1196	1166	
	200	1383	1347	1321	1295	1276	1256	
	500	1414	1395	1375	1359	1347	1335	
	1000	1431	1414	1403	1392	1384	1375	
	3000	1447	1438	1431	1424	1419	1414	
	5000	1453	1445	1441	1436	1432	1427	
BHP	200	50	93	137	179	222	265	5.9
	500	56	99	143	185	228	271	6.4
	1000	67	110	150	196	236	282	6.7
	3000	86	129	172	214	257	300	9.0
	5000	100	143	187	229	273	315	12.2
	10000	130	173	219	259	305	345	19.0
	12000	144	187	230	273	316	358	22.0

323F Rotor Size 630M								
Speed 720 RPM								
Viscosity SSU	Differential Pressure—PSI						Net Inlet Pressure Required (PSIA)	
	50	100	150	200	250	300		
USGPM	50	1041	968	—	—	—	—	
	100	1002	1041	1002	968	—	—	
	200	1129	1092	1064	1041	1020	2002	
	500	1161	1138	1120	1105	1092	1080	
	1000	1177	1161	1148	1138	1129	1120	
	3000	1194	1184	1177	1171	1166	1161	
	5000	1199	1191	1186	1181	1177	1173	
BHP	200	41	76	112	147	183	218	5.3
	500	46	81	116	152	187	223	5.5
	1000	50	86	121	157	192	228	5.8
	3000	65	100	136	171	207	242	7.0
	5000	76	111	147	182	218	253	8.4
	10000	98	133	169	204	240	275	12.5
	20000	131	166	202	237	273	308	20.0
	25000	145	181	216	252	287	323	24.0
Speed 690 RPM								
Viscosity SSU	Differential Pressure—PSI						Net Inlet Pressure Required (PSIA)	
	50	100	150	200	250	300		
USGPM	50	990	919	—	—	—	—	
	100	1042	990	951	919	—	—	
	200	1078	1042	1016	990	971	951	
	500	1109	1090	1070	1054	1042	1030	
	1000	1126	1109	1098	1087	1079	1070	
	3000	1143	1133	1126	1120	1115	1110	
	5000	1148	1140	1136	1131	1127	1122	
BHP	200	39	73	107	141	175	208	5.3
	500	42	76	111	144	179	212	5.4
	1000	47	81	116	149	184	217	5.4
	3000	61	95	129	163	197	231	6.8
	5000	70	104	139	172	207	240	7.8
	10000	90	124	159	192	227	260	11.3
	20000	119	153	190	221	258	289	17.3
	25000	135	169	203	237	271	305	20.0
Speed 570 RPM								
Viscosity SSU	Differential Pressure—PSI						Net Inlet Pressure Required (PSIA)	
	50	100	150	200	250	300		
USGPM	50	789	715	—	—	—	—	
	100	841	789	750	715	—	—	
	200	877	841	815	788	769	750	
	500	908	889	869	853	841	829	
	1000	925	908	897	886	878	869	
	3000	940	931	925	918	912	907	
	5000	947	939	935	930	926	921	
BHP	200	31	59	88	115	144	172	4.9
	500	34	62	90	118	147	175	4.9
	1000	37	65	94	121	150	178	5.1
	3000	47	75	103	131	159	187	5.7
	5000	53	81	110	137	166	193	5.9
	10000	66	94	123	150	180	206	7.8
	20000	87	115	144	171	201	227	12.0
	25000	97	125	153	182	210	238	13.5

323F Rotor Size 800J

Speed 1150 RPM

Viscosity SSU	Differential Pressure—PSI						Net Inlet Pressure Required (PSIA)	
	50	100	150	200	250	300		
USGPM	50	3128	3014	2924	—	—	—	
	100	3212	3128	3064	3014	2969	2924	
	200	3269	3211	3170	3128	3096	3064	
	500	3320	3283	3256	3231	3212	3192	
	1000	3347	3320	3300	3285	3271	3256	
	2000	3365	3347	3332	3320	3309	3300	
	3000	3373	3358	3347	3336	3328	3320	
BHP	200	122	222	323	420	522	620	9.8
	500	141	241	341	439	540	639	10.8
	1000	163	263	365	461	563	661	13.2
	2000	197	297	400	495	599	695	18.5
	3000	230	330	429	528	628	727	23.5

Speed 960 RPM

Viscosity SSU	Differential Pressure—PSI						Net Inlet Pressure Required (PSIA)	
	50	100	150	200	250	300		
USGPM	50	2564	2447	2357	—	—	—	
	100	2646	2564	2500	2447	2399	2356	
	200	2705	2646	2601	2564	2530	2500	
	500	2756	2720	2691	2667	2646	2627	
	1000	2783	2757	2737	2720	2705	2691	
	3000	2809	2794	2783	2773	2764	2757	
	5000	2818	2806	2797	2789	2783	2777	
BHP	200	100	183	266	349	432	515	7.3
	500	113	196	279	362	445	528	7.8
	1000	129	212	295	378	461	544	8.8
	3000	175	258	341	424	507	590	13.0
	5000	208	292	375	458	541	624	17.5
	7500	244	328	410	493	576	659	25.0

Speed 870 RPM

Viscosity SSU	Differential Pressure—PSI						Net Inlet Pressure Required (PSIA)	
	50	100	150	200	250	300		
USGPM	50	2298	2184	2094	—	—	—	
	100	2382	2298	2234	2184	2139	2094	
	200	2439	2381	2340	2298	2266	2234	
	500	2490	2453	2426	2401	2382	2362	
	1000	2517	2490	2473	2455	2441	2426	
	3000	2543	2528	2517	2506	2498	2490	
	5000	2552	2540	2532	2524	2517	2510	
BHP	200	88	163	240	314	390	464	6.6
	500	99	174	251	325	401	475	7.1
	1000	118	193	264	344	414	494	7.8
	3000	151	226	301	376	452	527	10.5
	5000	176	252	329	403	479	553	14.7
	10000	229	304	384	454	535	602	25.0

323F Rotor Size 800J

Speed 720 RPM

Viscosity SSU	Differential Pressure—PSI						Net Inlet Pressure Required (PSIA)	
	50	100	150	200	250	300		
USGPM	50	1852	1735	1645	—	—	—	
	100	1935	1852	1789	1735	1688	—	
	200	1993	1935	1890	1852	1819	1789	
	500	2045	2008	1980	1956	1935	1916	
	1000	2071	2045	2025	2008	1993	1980	
	3000	2098	2083	2071	2062	2053	2045	
	5000	2106	2094	2086	2078	2071	2065	
	BHP	200	72	134	196	259	321	383
500		79	142	204	266	328	391	5.8
1000		89	151	213	275	338	400	6.2
3000		114	176	239	301	363	425	7.7
5000		133	196	258	320	382	445	9.6
10000		171	234	296	358	421	483	15.5
20000		230	292	354	417	479	541	27.5

Speed 690 RPM

Viscosity SSU	Differential Pressure—PSI						Net Inlet Pressure Required (PSIA)	
	50	100	150	200	250	300		
USGPM	50	1764	1648	1556	—	—	—	
	100	1847	1764	1699	1648	1602	1556	
	200	1904	1846	1805	1764	1732	1699	
	500	1955	1919	1891	1866	1847	1827	
	1000	1982	1955	1937	1918	1905	1891	
	3000	2009	1994	1982	1973	1964	1956	
	5000	2017	2005	2002	1999	1988	1976	
BHP	200	68	128	188	246	307	367	5.4
	500	75	135	195	253	314	374	5.7
	1000	83	143	203	261	323	382	6.0
	3000	107	167	227	286	346	406	7.4
	5000	123	183	244	302	364	422	8.8
	10000	158	218	279	337	399	457	13.8
	20000	207	266	333	385	452	505	23.7

Speed 570 RPM

Viscosity SSU	Differential Pressure—PSI						Net Inlet Pressure Required (PSIA)	
	50	100	150	200	250	300		
USGPM	50	1408	1294	1201	—	—	—	
	100	1492	1408	1344	1294	1243	—	
	200	1549	1491	1450	1408	1376	1344	
	500	1600	1564	1536	1511	1492	1472	
	1000	1627	1600	1582	1563	1550	1536	
	3000	1653	1638	1627	1617	1608	1600	
	5000	1662	1650	1642	1634	1627	1620	
	BHP	200	55	104	154	202	253	301
500		60	109	159	207	257	306	5.1
1000		65	114	164	213	263	311	5.3
3000		82	131	181	230	279	328	6.1
5000		93	142	193	241	291	339	6.7
10000		116	165	217	264	315	362	9.3
20000		153	202	254	301	352	399	13.5
25000		171	220	269	319	368	417	15.8

1. For conditions between listed values, interpolate between those values. For conditions not listed or off tables, contact IMO. See page 8 for an interpolation example.
2. Net Inlet Pressure Required is minimum pressure above vapor pressure at pump inlet to prevent cavitation. This assumes that the fluid is air and gas free.
3. For BHP values at viscosities below 200 SSU, use values listed for 200 SSU.

Typical Pump/Driver Arrangement

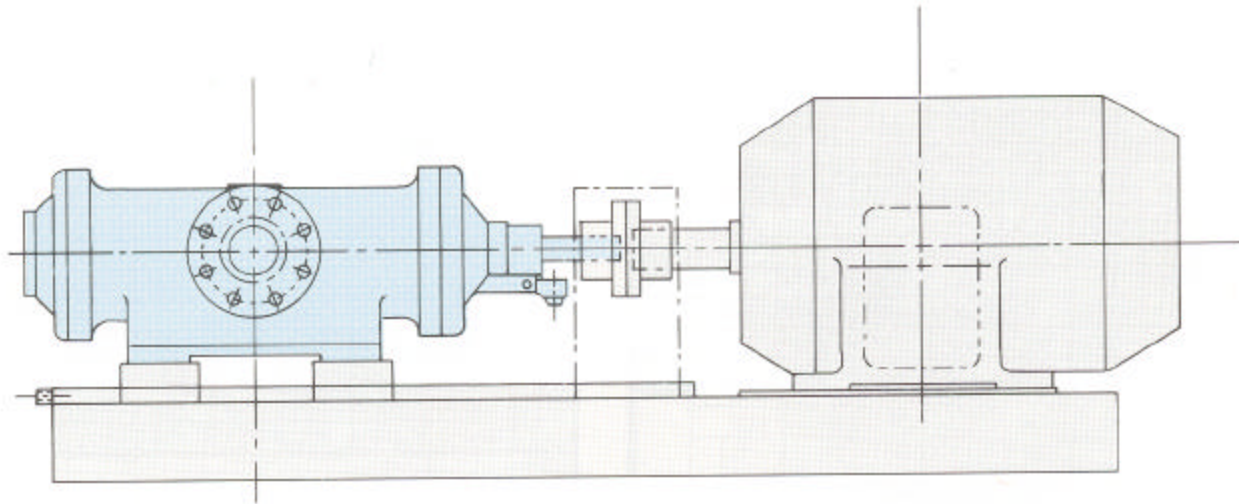

323 F HORIZONTAL FOOT MOUNTED PUMP/MOTOR ASSEMBLY

Note: Includes pump and motor with OSHA type coupling guard and shaft coupling factory mounted on a steel baseplate (with or without dripim). Other pump/driver arrangements or variations are also available. Consult IMO.

Interpolation Example

323F Rotor Size 630M							
Speed 1150 RPM							
Viscosity SSU	Differential Pressure—PSI						
	50	100	150	200	250	300	Net Inlet Pressure Required (PSIA)
USGPM	50	1770	1699	1643	—	—	
	100	1822	1770	1731	1699	1671	1643
	200	1858	1822	1796	1770	1750	1731
	500	1889	1870	1850	1834	1822	1810
	1000	1906	1889	1878	1867	1859	1850
	3000	1920	1911	1906	1897	1892	1887
	5000	1928	1920	1916	1911	1907	1902
BHP	200	70	126	184	240	297	353
	500	81	137	195	251	308	364
	1000	93	150	208	263	321	377
	3000	131	188	244	301	358	414
	5000	178	212	272	325	385	438

A linear interpolation is accurate between any two adjacent numbers tabulated. Following example demonstrates how to interpolate.

Rated USGPM & BHP at 200 SSU, 265 psi

(1) 1750 USGPM - 1731 USGPM = 19 USGPM

265 psi - 250 psi = 15 psi

300 psi - 250 psi = 50 psi

$$\frac{15}{50} \times 19 = 5.7 \text{ USGPM}$$

$$1750 \text{ USGPM} - 5.7 \text{ USGPM} = 1744.3 \text{ USGPM}$$

(2) 353 BHP - 297 BHP = 56 BHP

$$\frac{15}{50} \times 56 = 16.8 \text{ BHP}$$

$$297 \text{ BHP} + 16.8 \text{ BHP} = 313.8 \text{ BHP}$$

Series 323F Pump Dimensions

All dimensions are in inches.
Standard rotation : clockwise

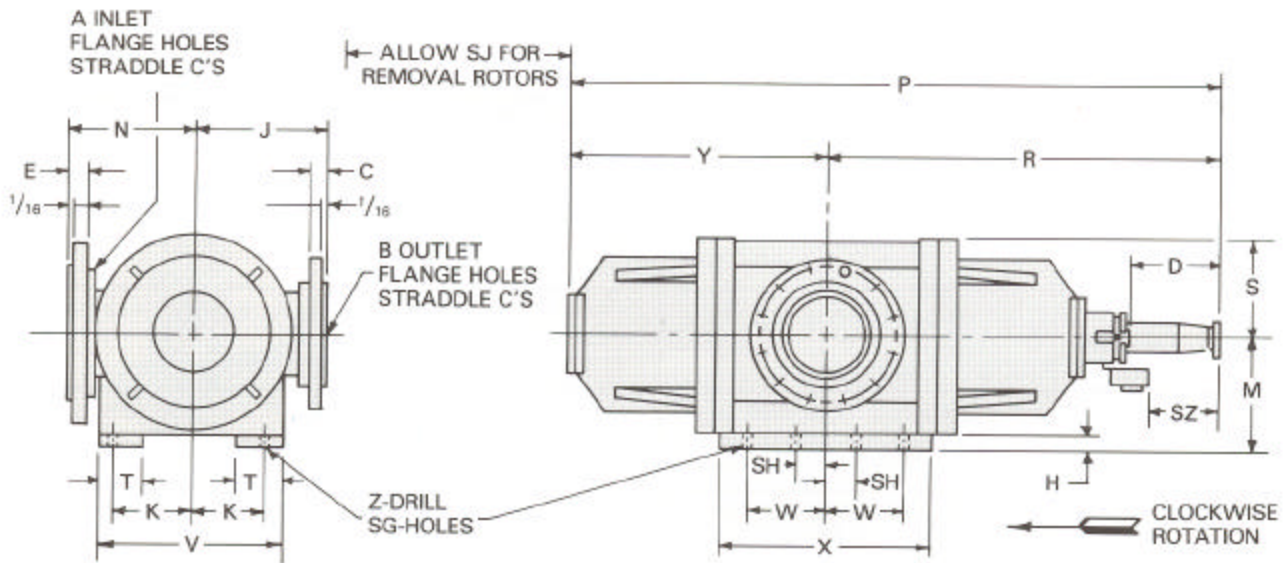
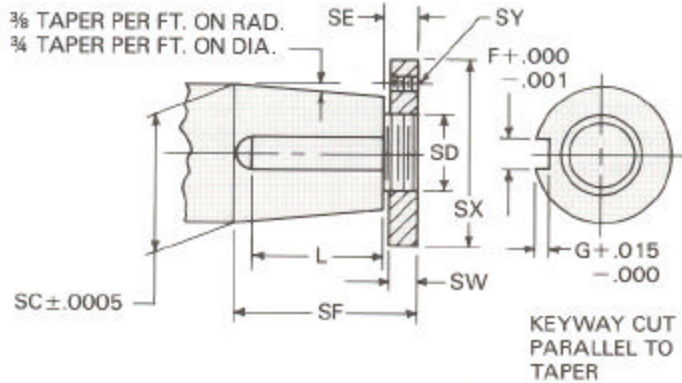

Standard inlet and outlet position shown. Reversed inlet and outlet positions can be provided.

PUMP SIZE	A	B	C	D	E	F	G	H	J	K	L	M	N	P	R	S	T	WT. LBS.
323F-550J	10	8	1 1/8	4 15/16	1 1/8	.625	.327	1	13	7 1/2	2 21/32	11	12	52 3/8	30 3/4	9 1/2	4	1550
323F-550	10	8	1 1/8	4 9/16	1 1/8	.625	.327	1	13	7 1/2	2 21/32	11	12	60 3/8	34 3/4	9 1/2	4	1550
323F-630M	12	10	1 1/8	5 3/16	2	.625	.327	1	16	8 1/2	2 21/32	12	14 3/4	63 3/8	36 3/4	10 3/8	4 3/8	1950
323F-800J	12	10	1 1/8	6 1/2	2	.875	.453	1 1/4	16	10 1/2	4 1/8	17 3/4	15	74 5/16	43 1/8	12 3/4	7	2550
PUMP SIZE	V	W	X	Y	Z	SC	SD	SE	SF	SG	SH	SJ	SW	SX	SY	SZ		
323F-550J	18	7 3/4	21	22 1/8	1	2.750	1 1/2-12	3/8	3 19/32	4	—	50	9/16	3 3/4	3/8-16	4 5/16		
323F-550	18	7 3/4	21	26	1	2.750	1 1/2-12	3/8	3 19/32	4	—	53	9/16	3 3/4	3/8-1	3 3/8		
323F-630M	20 3/4	9 1/4	25	27	1 1/8	2.750	1 1/2-12	3/8	3 19/32	4	—	57	9/16	3 3/4	3/8-16	4 9/16		
323F-800J	25 1/2	9 1/2	27	31 3/16	1 1/4	3.750	2 1/4-12	3/8	5	8	3	63	13/16	5	1/2-13	5 3/8		

*Cast iron cased pumps have 250# FF flanges.
Cast steel cased pumps have 300# FF flanges.
Fabricated steel cased pumps (800J size) have 300# RF flanges.

OFFICE	ROTATION <input type="checkbox"/> CW <input type="checkbox"/> CCW(D)	CASE MATERIAL <input type="checkbox"/> IRON <input type="checkbox"/> STEEL	CERTIFIED BY	DATE
CUSTOMER	CUSTOMER ORDER			
MODEL NO	IMO ORDER			

How To Specify IMO Series 323F Pumps

Specification	Benefit
Pump shall be untimed double end IMO rotary 3-screw design with complete radial and axial hydraulic balance and no ball or roller bearings.	Simple—only three rotating parts—rugged construction insures long life with little or no maintenance. No bearing problems—less maintenance. Long pump life due to no bending loads.
Pump shall not require lubrication or cooling.	Lower maintenance costs. Lower installation cost. No cooling water or piping expense.
Pump shall be equipped with only one suction pressure seal chamber.	Fewer seals mean reduced initial cost, reduced downtime and spare parts cost. Seal only exposed to suction pressure results in reduced load and long life.
Pump shall neither require nor include radial support bearings or timing gears.	Fewer parts leads to less maintenance, less downtime, lower initial cost.
Pump shall provide smooth, continuous flow free of pulsation and vibration.	Pulsation dampening equipment and resulting expense and maintenance are not required.
Pump shall handle complete range of viscosity and pressure as specified.	Reduces number and types of pumps required—lower installation cost. Highly predictable and uniform operating characteristics allows for more installation flexibility.
Pump shall be self priming and capable of evacuating air filled inlet lines.	Allows more installation flexibility with lower installation cost.
Pump shall employ unmatched rotor sets.	Damage to one rotor does not mandate replacement of all rotors—lower repair costs.
Pump shall be equipped with replaceable rotors and rotor housings with separate non-wearing case.	Complete field reparability—less downtime and repair cost without need for factory-based overhaul. Separate non-wearing case is an added safety feature.
Each pump shall be full load tested prior to shipment.	Assures user that pump will provide trouble-free operation.
Pump noise shall be 80 dBA (or below) sound pressure level overall at three feet.	Meets OSHA requirements. Costly noise abatement equipment not required. Increases employee productivity.
Pump shall be furnished with standard full twelve months warranty.	Assurance of a reliable product completely backed by Imo Delaval.

Viscosity Conversion Table

The following table will give a comparison of various viscosity ratings so that if the viscosity is given in terms other than Saybolt Universal, it can be translated quickly by following horizontally to the Saybolt Universal column.

Saybolt Universal Viscosity SSU	Kinematic Viscosity Centistokes	Saybolt Furol	Seconds Redwood (Standard)	Seconds Redwood 2 (Admiralty)	Degrees Engler	Degrees Barbery	Seconds Parlin Cup #7	Seconds Parlin Cup #10	Seconds Parlin Cup #15	Seconds Parlin Cup #20	Seconds Ford Cup #3	Seconds Ford Cup #4	Approx. Mac Michael	Approx. Gardner Holt Bubble	Seconds Zahn Cup #1	Seconds Zahn Cup #2	Seconds Zahn Cup #3	Seconds Zahn Cup #4	Seconds Zahn Cup #5	Seconds Denmler Cup #1	Seconds Denmler Cup #10	Approx. Stormer 100 gm Load	Seconds Pratt and Lambert "F"	Seconds Saybolt Universal SSU
32	1.82	-	30.8	-	1.14	-	-	-	-	-	-	-	-	-	-	-	-	-	-	-	-	-	-	32
35	2.71	-	32.1	-	1.16	2420	-	-	-	-	-	-	-	-	-	-	-	-	-	-	-	-	-	35
40	4.25	-	36.2	5.10	1.31	1440	-	-	-	-	-	-	-	-	-	-	-	-	-	1.3	-	-	-	40
50	7.68	-	44.3	5.83	1.58	838	-	-	-	-	-	-	-	-	-	-	-	-	-	2.3	2.6	-	-	50
60	10.3	-	52.3	6.77	1.88	618	-	-	-	-	-	-	-	-	-	-	-	-	-	3.2	3.6	-	-	60
70	13.1	12.95	60.9	7.60	2.17	483	-	-	-	-	-	-	-	-	-	-	-	-	-	4.1	4.6	-	-	70
80	15.7	13.70	69.2	8.44	2.45	404	-	-	-	-	-	-	-	-	-	-	-	-	-	4.9	5.5	-	-	80
90	18.1	14.44	77.6	9.30	2.73	348	-	-	-	-	-	-	-	-	-	-	-	-	-	5.7	6.4	-	-	90
100	20.5	15.24	85.6	10.12	3.02	307	-	-	-	-	-	-	125	-	38	18	-	-	-	6.5	7.3	-	-	100
150	31.9	19.30	128	14.48	4.48	195	-	-	-	-	-	-	145	-	47	20	-	-	-	10.0	11.3	-	-	150
200	43.0	23.5	170	18.90	5.92	144	40	-	-	-	-	-	165	A	54	23	-	-	-	13.5	14	15.2	-	200
250	53.8	28.0	212	23.45	7.35	114	46	-	-	-	-	-	198	A	62	26	-	-	-	16.9	17	19	-	250
300	64.6	32.5	254	28.0	8.79	95	52.5	15	6.0	3.0	30	20	225	B	73	29	-	-	-	20.4	2.0	23	-	300
400	86.2	41.9	338	37.1	11.70	70.8	66	21	7.2	3.2	42	28	270	C	90	37	-	-	-	27.4	2.7	31	7	400
500	108	51.6	423	46.2	14.60	56.4	79	25	7.8	3.4	50	34	320	D	-	46	-	-	-	34.5	3.5	39	8	500
600	130	61.4	508	55.4	17.50	47.0	92	30	8.5	3.6	58	40	370	F	-	55	-	-	-	41	4.1	46	9	600
700	151	71.1	592	64.6	20.45	40.3	106	35	9.0	3.9	67	45	420	G	-	63	22.5	-	-	48	4.8	54	9.5	700
800	173	81.0	677	73.8	23.35	35.2	120	39	9.8	4.1	74	50	470	-	-	72	24.5	-	-	55	5.5	62	10.8	800
900	194	91.0	762	83.0	26.30	31.3	135	41	10.7	4.3	82	57	515	H	-	80	27	18	-	62	6.2	70	11.9	900
1000	216	100.7	896	92.1	29.20	28.2	149	43	11.5	4.5	92	62	570	I	-	88	29	-	-	69	6.9	77	12.4	1000
1500	324	150	138.2	138.2	43.80	18.7	-	65	15.2	6.3	132	90	805	M	-	-	40	28	18	103	10.3	116	16.8	1500
2000	432	200	1690	184.2	58.40	14.1	-	86	19.5	7.5	172	118	1070	Q	-	-	51	34	24	137	13.7	154	22	2000
2500	539	250	2120	230	73.0	11.3	-	108	24	9	218	147	1325	T	-	-	63	41	29	172	17.2	193	27.6	2500
3000	648	300	2540	276	87.60	9.4	-	129	28.5	11	258	172	1690	U	-	-	75	48	33	206	20.6	232	33.7	3000
4000	862	400	3380	368	117.0	7.05	-	172	37	14	337	230	2110	V	-	-	63	43	43	275	27.5	308	45	4000
5000	1079	500	4230	461	146	5.64	-	215	47	18	425	290	2635	W	-	-	77	50	50	344	34.4	385	55.8	5000
6000	1295	600	5080	553	175	4.70	-	258	57	22	520	350	3145	X	-	-	-	65	65	413	41.3	462	65.5	6000
7000	1510	700	5920	645	204.5	4.03	-	300	67	25	600	410	3670	-	-	-	-	-	75	481	48	540	77	7000
8000	1726	800	6770	737	233.5	3.52	-	344	76	29	680	465	4170	Y	-	-	-	-	86	550	55	618	89	8000
9000	1942	900	7620	829	263	3.13	-	387	86	32	780	520	4700	Z	-	-	-	-	96	620	62	695	102	9000
10000	2160	1000	8460	921	292	2.82	-	430	96	35	850	575	5220	-	-	-	-	-	-	690	69	770	113	10000
15000	3240	1500	13700	-	438	2.50	-	650	147	53	1280	860	7720	Z2	-	-	-	-	-	1030	103	1160	172	15000
20000	4320	2000	18400	-	584	1.40	-	860	203	70	1715	1150	10500	Z3	-	-	-	-	-	1370	137	1540	234	20000

* Kinematic Viscosity (in centistokes) = $\frac{\text{Absolute viscosity (in centipoises)}}{\text{Specific Gravity}}$

Above 300 SSU, use the following approximate conversion
SSU = Centistokes x 4.635

Above the range of this table and within the range of the viscosimeter, multiply their rating by the following factors to convert to SSU.

Viscosimeter	Factor	Viscosimeter	Factor	Viscosimeter	Factor
Saybolt Furol	10	Parlin cup #15	98.2	Mac Michael	1.92 (approx.)
Redwood Standard	1.095	Parlin cup #20	187.0	Denmler #1	14.6
Redwood Admiralty	10.87	Ford cup # 4	17.4	Denmler #10	146.
Engler Degrees	34.5			Stormer	13. (approx.)

Typical 323F Nomenclature

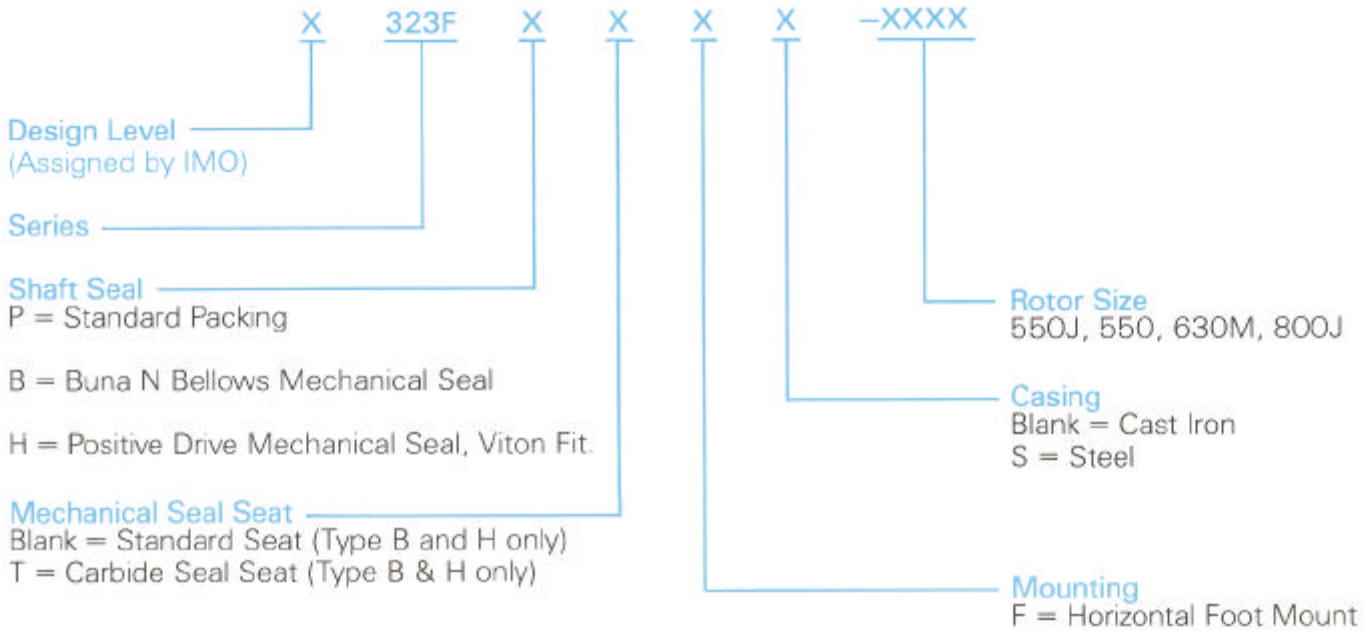

Examples:

- 323FPF-550J (323F pump with standard shaft packing, foot mount, cast iron casing, rotor size 550J)
- 323FBFS-630M (323F pump with Buna N bellows mechanical seal, foot mount, steel casing, rotor size 630M)

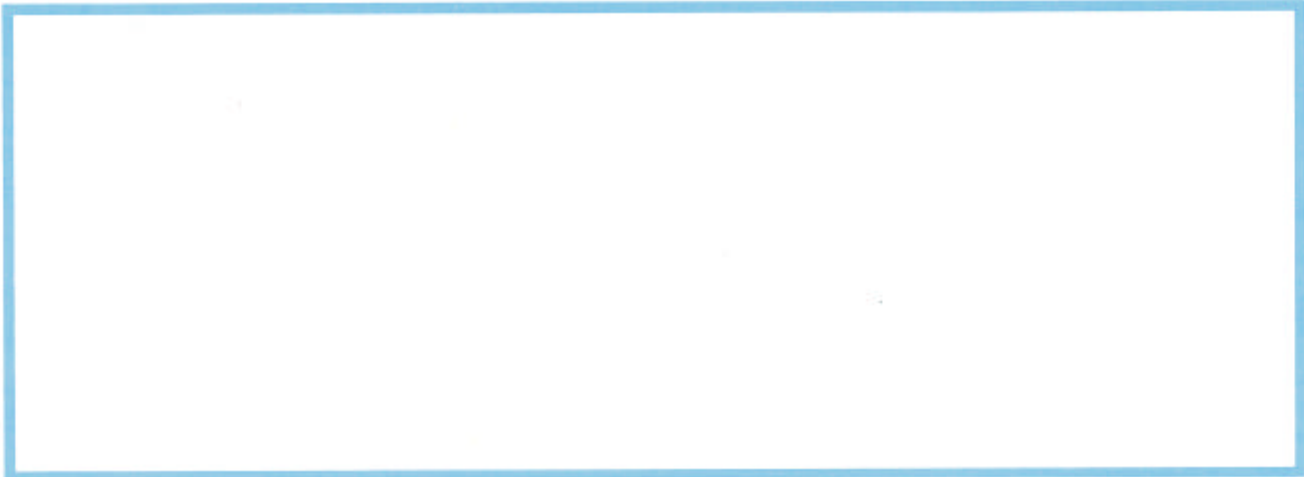

For additional sales and service information, contact your local Imo Sales Representative.



Quality Management System



Imo Pump
1710 Airport Road
PO Box 5020
Monroe, NC USA
28111.5020

tel 704.289.6511
fax 704.289.9273
e-mail Imo.Pump@ColfaxCorp.com
web WWW.IMO-PUMP.COM