

ACE4 OptiLine

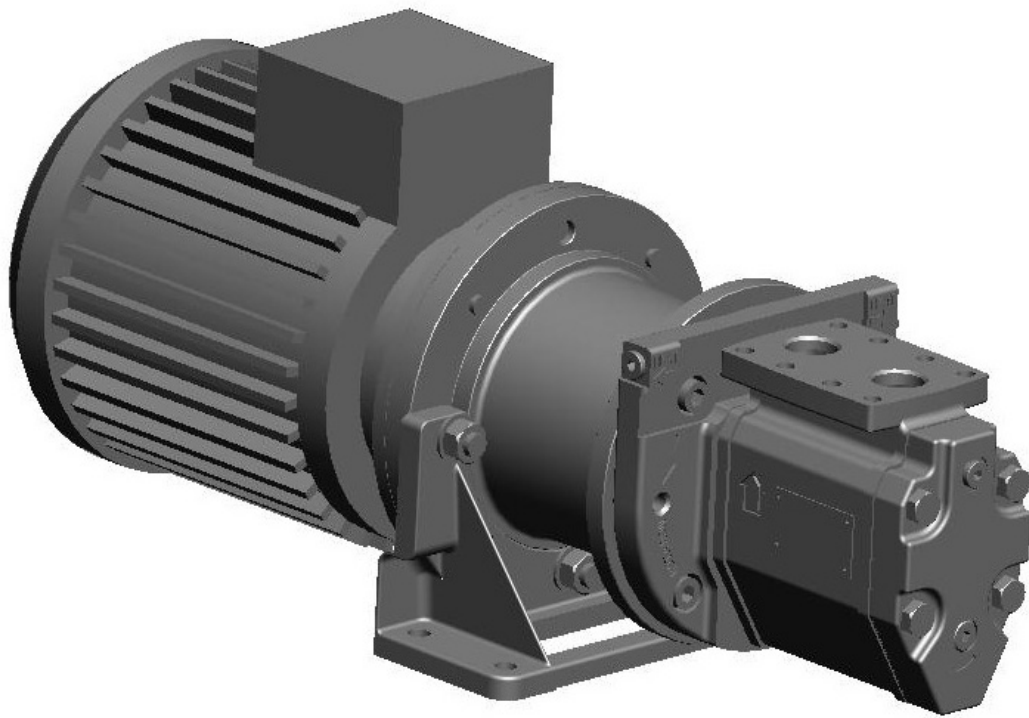

Product Description



Flow volume:	8 - 175 l/min
Max differential pressure:	16 bar
Applications:	Circulation and transfer

1. Applications

1.1 Functionality

The ACE OptiLine pump is used for a number of different fluids:

Fuel oil, vegetable oil, hydraulic oil and other hydraulic fluids, polymers, emulsions and any non-aggressive fluid with sufficient lubricating properties.

If requested, the ACE pump may be certified according to any of following classification societies: DNV, BV, LRS, ABS, RS, GL, RINA, KR, NK, RMR or CCS.

1.2 Applications

Typical applications are:

- Lubrication of diesel engines, gears, gas and steam turbines, hydro turbines and paper machines
- Circulation for cooling and filtration in large machineries, hydraulic systems and transformer oil for insulation in transformers
- Transfer onboard ships, in oil factories, refineries, tank farms etc
- Fuel supply duties for diesel engines

1.3 Installation

The pump is designed to be flange-mounted to its electric motor via a connecting frame and a magnetic coupling. By the angle bracket, the pump might be mounted horizontally or vertically. The ACE pump can also be mounted on valve blocks called T4 or T5.

As standard, the pump is delivered including counter flanges (IMO AB design).

For more information about installation, see Service, Maintenance and Installation for ACE OptiLine generation 4.

2. Pump model code

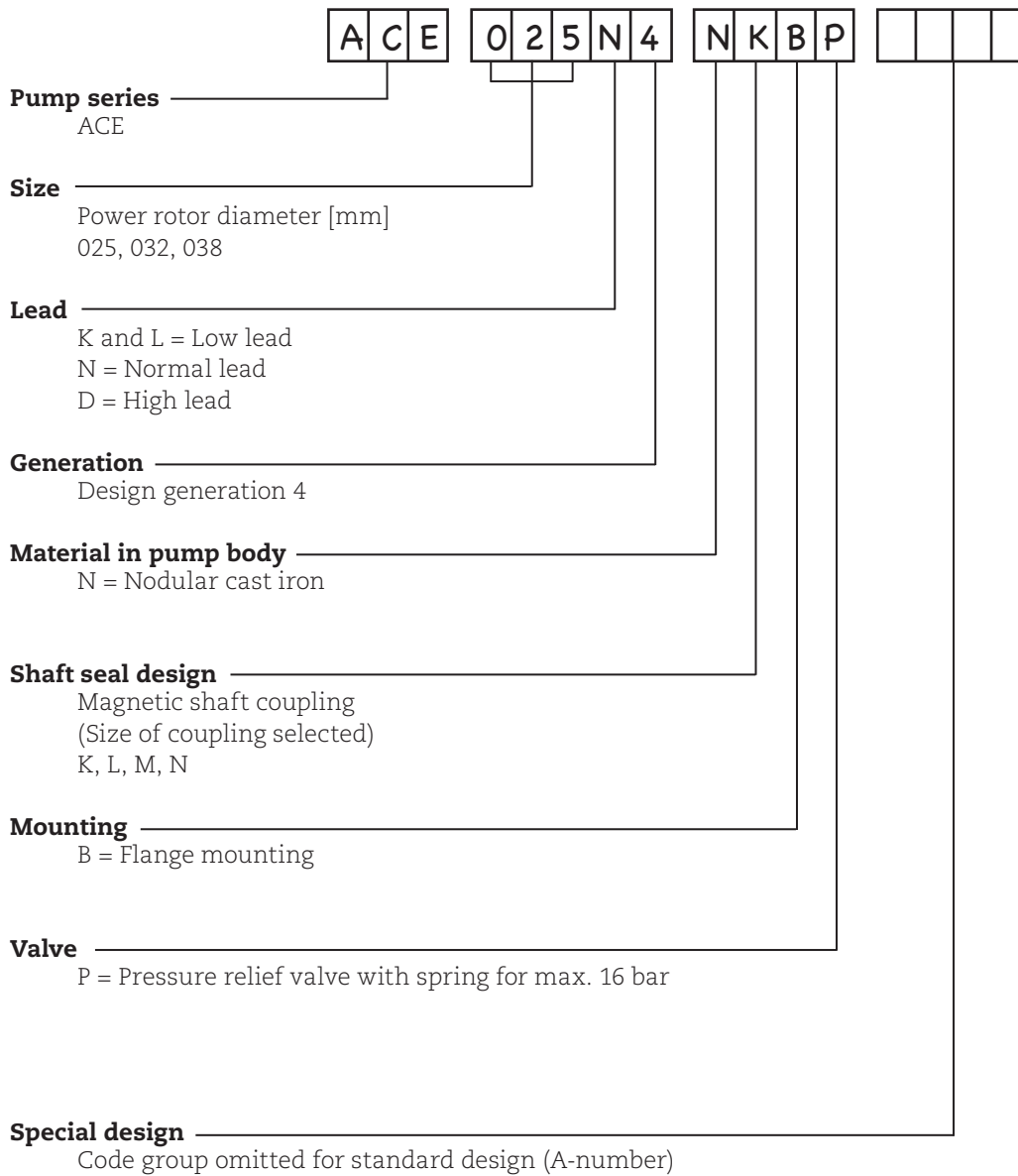

3. Technical Data

3.1 Pressure Information

Pressure relief valve

The pump is equipped with an integral pressure relief valve with internal return, limiting the differential pressure across the pump and protecting the pump. Should the discharge line be blocked, the relief valve will open by the pressure.

The valve is adjustable for different opening pressures. The value of the pressure limit can be set at the factory and should be adjusted at installation (see Service, Maintenance and Installation for ACE OptiLine generation 4).

The maximum pressure accumulation varies with pump size, speed and viscosity, but will normally not exceed 4 bar.

The valve has a maximum set pressure of 16 bar.

Inlet pressure

Minimum inlet pressure (suction capability) is dependent on fluid viscosity and rotation speed. It increases with decreasing viscosity and decreasing speed. Information about minimum inlet pressure for each individual duty case can be obtained from IMO AB or pump selection software WinPump.

Maximum inlet pressure is 7 bar.

Discharge pressure

Maximum discharge pressure is 16 bar.

Differential pressure

Maximum differential pressure is 16 bar but reduced at low viscosities according to table below

Viscosity [cSt]	1,4	2	6	10	>12
Max. diff. pressure [bar]	6,9	8	12,4	15	16

Refer to your IMO representative or use the pump selection software WinPump to determine the exact operating limits.

3.2 Driver information

Driver type

The power from motor to the OptiLine ACE pump is transmitted without mechanical contact over a magnetic coupling. A coupling hub with a set of permanent magnets is mounted on the pump shaft. This hub is totally enclosed by a stainless steel can. The motor hub with another set of permanent magnets rotates on the outside of this can.

Thus the pumped liquid is totally confined within the pump without the use of a conventional shaft seal.

The pump is designed for this type of drive only.

Speed

The maximum speed is 3600 rpm. For higher speeds, contact IMO AB.

Rotation

The pump is designed to operate in one rotational direction only, as standard clockwise when facing the shaft end. Pumps for CCW operation can be delivered on special request.

For shorter periods of time, a few minutes for emptying a discharge line, the pump may be operated in reverse direction, provided the back pressure is limited to 3 bar.

3. Technical Data

3.3 Sound level

Typical pump sound levels refer to free field conditions at a distance of 1 m from the pump. Noise of driver excluded in the quoted figures. The sound levels are measured at a discharge pressure of 5 bar, speed 2940 rpm and viscosity 40 cSt, according to ISO-3741.

Size	025	032	038
Sound level dB [A]	58	58	58

3.4 Moment of Inertia

Moment of inertia [10^{-6} kgm²]

Coupling / size	025	032	038
K	3692	3715	-
L	5730	5753	5908
M	-	6917	7072
N	-	-	7594

3.5 Magnetic shaft coupling

< Torque values (greater than, at least) [Nm]

	Size		
Coupling	025	032	038
K	7	7	-
L	14	14	14
M	-	22	22
N	-	-	30

3.6 Fluid viscosity

OptiLine pumps:

1,4 – 1500 cSt

For higher viscosity, contact IMO AB.

3.7 Fluid temperature

OptiLine pumps:

-20 – +180 °C

4. Design

4.1 Ball bearing

The pump is fitted with an internal ball bearing which continuously is being greased by the handling media.

4.2 Design material

Model	Material pump	Material rotor	Material idler	Material seal	Material Elastomers
ACE	Nodular cast iron	Steel, surface treated	Cast iron, surface treated	-	Viton

4.3 Steam tracing

During cold start-up conditions, high viscosity could cause the rated torque for the coupling to be exceeded.

The IMO OptiLine pump series have a way to warm up the pump by leading steam into small channels at the front cover. This is recommended if cold upstart can be assumed.

See Pump Unit Dimensions for dimensions of the connections to the steam system.

5. Performance

Typical performance values at 5 bar
Flow calculated at 26 cSt, power at 260 cSt.

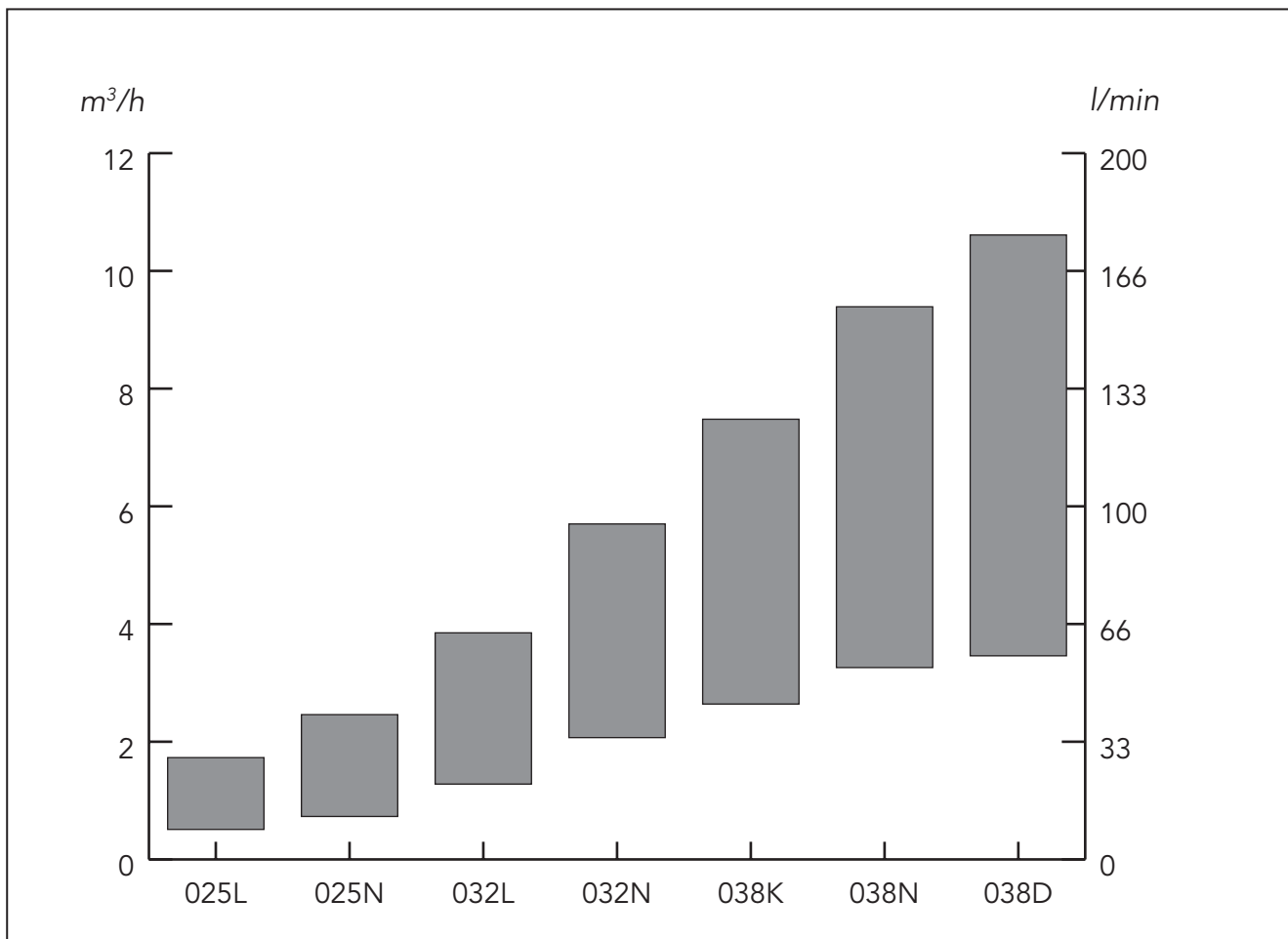

025L			025N		
rpm	l/min	kW	l/min	kW	
1470	8,5	0,3	12,1	0,4	
1770	11,5	0,4	16,3	0,5	
2950	23,1	0,8	32,7	1,0	
3550	28,9	1,1	41,0	1,3	

032L			032N		
rpm	l/min	kW	l/min	kW	
1470	21,4	0,5	34,5	0,7	
1770	27,5	0,6	43,2	1,0	
2950	51,8	1,4	77,5	1,9	
3550	64,2	1,9	95,0	2,5	

038K			038N			038D		
rpm	l/min	kW	l/min	kW		l/min	kW	
1470	44,0	1,3	54,3	1,2		57,6	1,3	
1770	57,1	1,6	69,1	1,5		74,8	1,6	
2950	101,5	3,4	127,0	3,2		143,9	3,4	
3550	124,7	4,3	156,5	4,1		176,8	4,3	

6. Sectional view

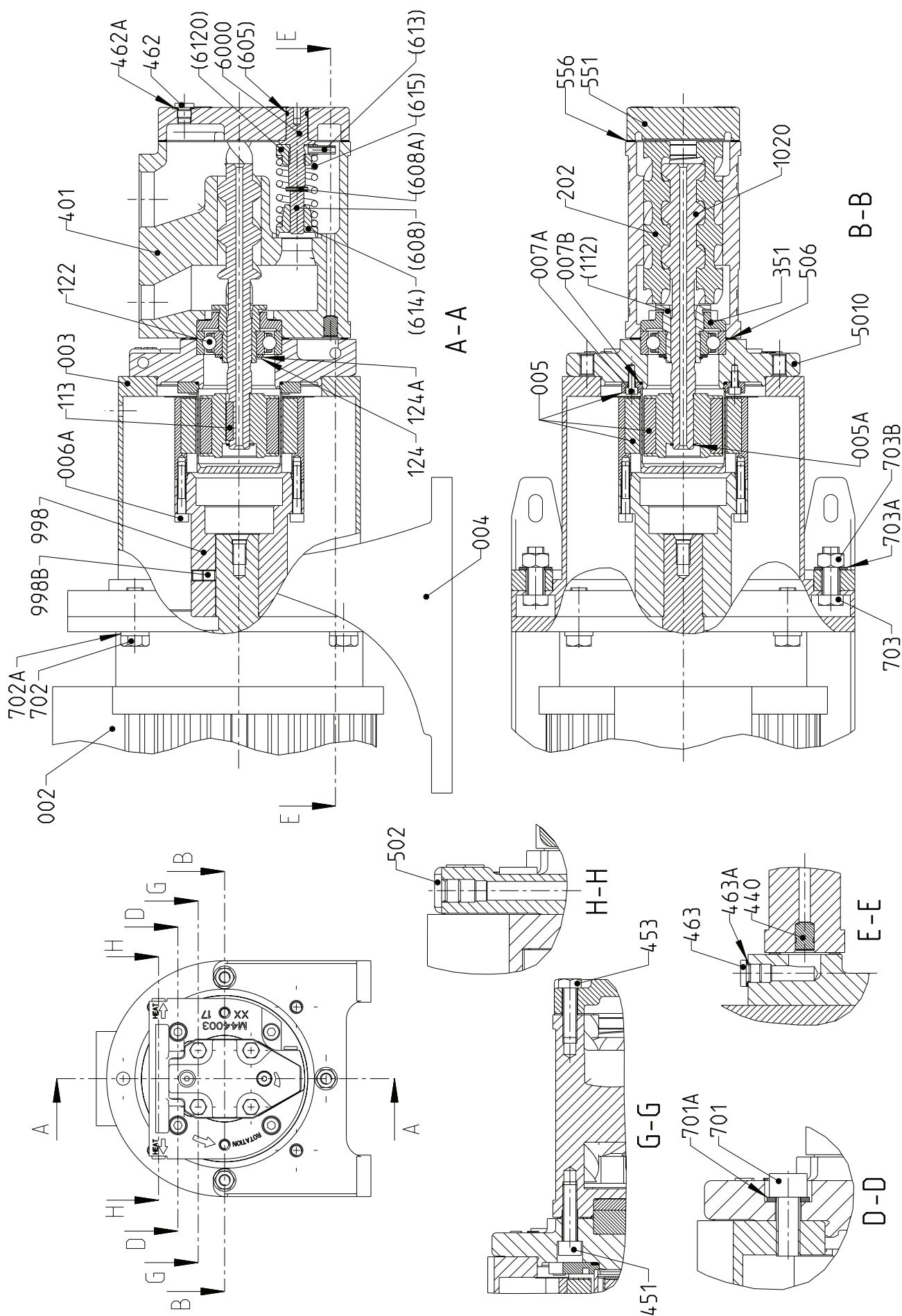

7. List of components

Pos No	Denomination	Pos No	Denomination	Pos No	Denomination
002	Motor	401	Pump body	(608)	Valve spindle
003	Connecting frame	440	Expander plug	(608A)	Tension pin
004	Angle bracket	451	Screw	(6120)	Complete regulating nut
005	Magnetic coupling	453	Screw	(613)	Pin
005A	Retaining ring	462	Plug	(614)	Valve piston
006A	Screw	462A	Sealing washer	(615)	Valve spring
007A	Screw	463	Plug	701	Screw
007B	O-ring	463A	Sealing washer	701A	Washer
1020	Complete power rotor	5010	Front cover	702	Screw
(112)	Balancing piston	502	Plug	702A	Washer
113	Key	506	Gasket	703	Screw
122	Ball bearing	551	Rear cover	703A	Washer
124	Retaining ring	556	Gasket	703B	Nut
124A	Support ring	6000	Complete valve element	998	Drive hub
202	Idler rotor	(605)	O-ring	998B	Screw
351	Balancing bush				

Notes:

- Components with Pos No within parenthesis are parts of subassembly

8. Pump dimensions

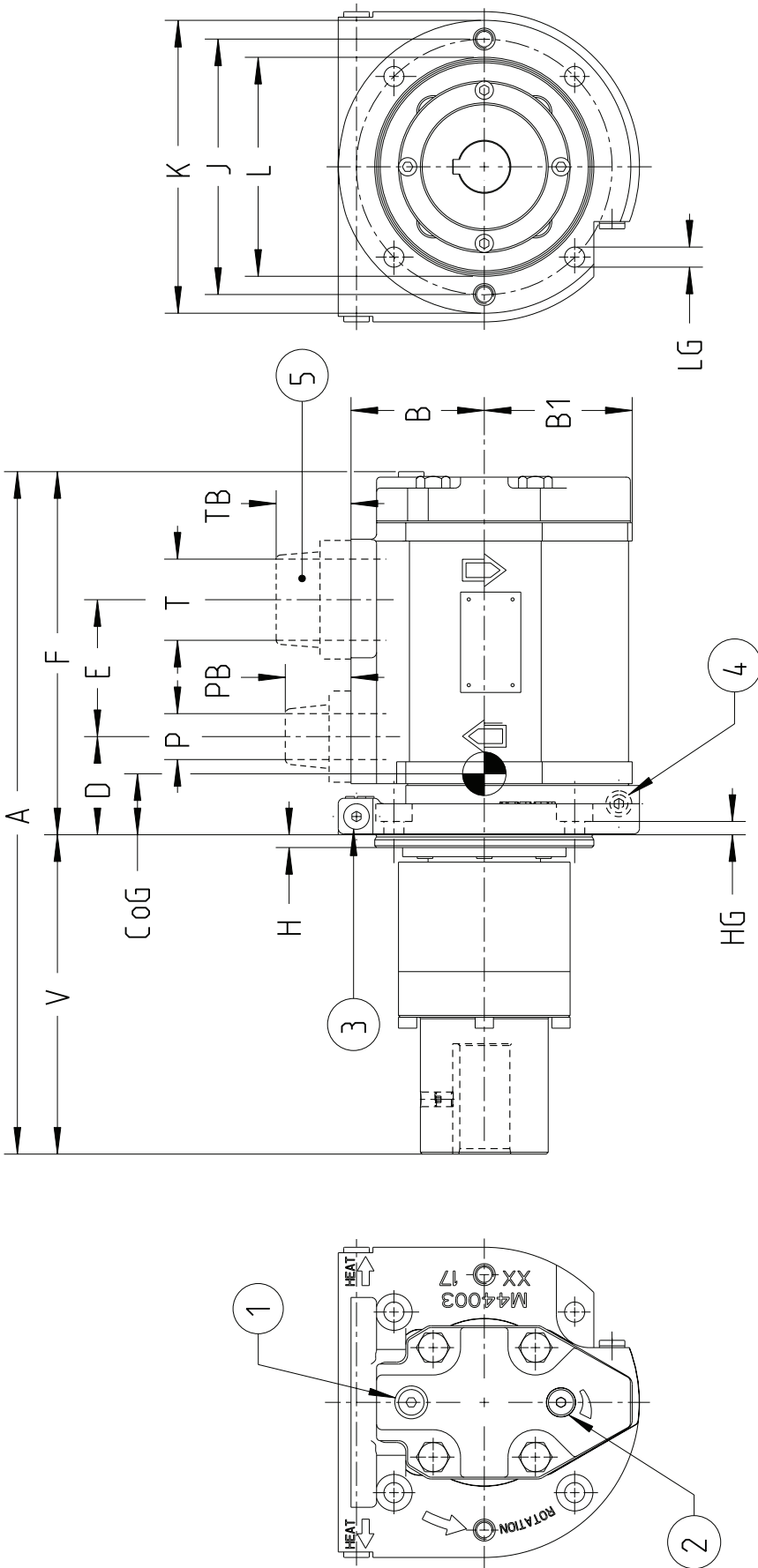

8. Pump dimensions

Pump size	IEC No	Frame size	Main dim.						Flange dim.						Outlet		Inlet		Weight	
			A	B	B1	D	E	F	V	HG	H	J	K	L ¹⁾	LG	P	PB	T	TB	CoG
025	80	F165	303					140									25	37	26	15
	90																			
	100	F215	338	46	60	163		140											22	19
	112																			
032	80	F165	339	73	81			140	8	7	140	160	120	11			40	42	51	20
	90																			
	100	F215	374	54	75	199		140											46	21
	112																			
038	80	F165	346					140											46	20
	90																			
	100	F215	381	83	83	206		140											34	21
	112																			
	132	F265	402					196											27	22

Drawing remarks:

(1) Inlet gauge. ISO G1/8

(2) Relief valve. Turn clockwise to increase opening pressure

(3) Connection for heating. ISO G1/8

(4) Other side: Outlet gauge. ISO G1/8

(5) For dimensions of Butt weld counter flanges see Pump unit dimensions on page 12

Notes:

- Dimensions in mm

1) Tolerances ISO h7

9. Pump Unit dimensions

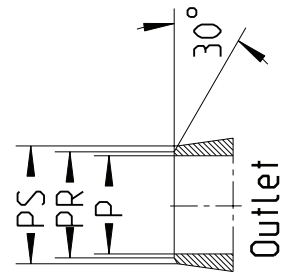
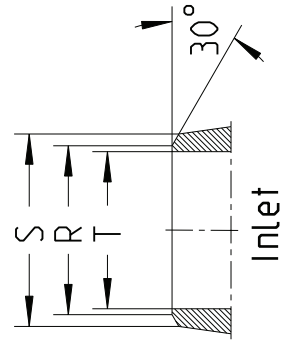
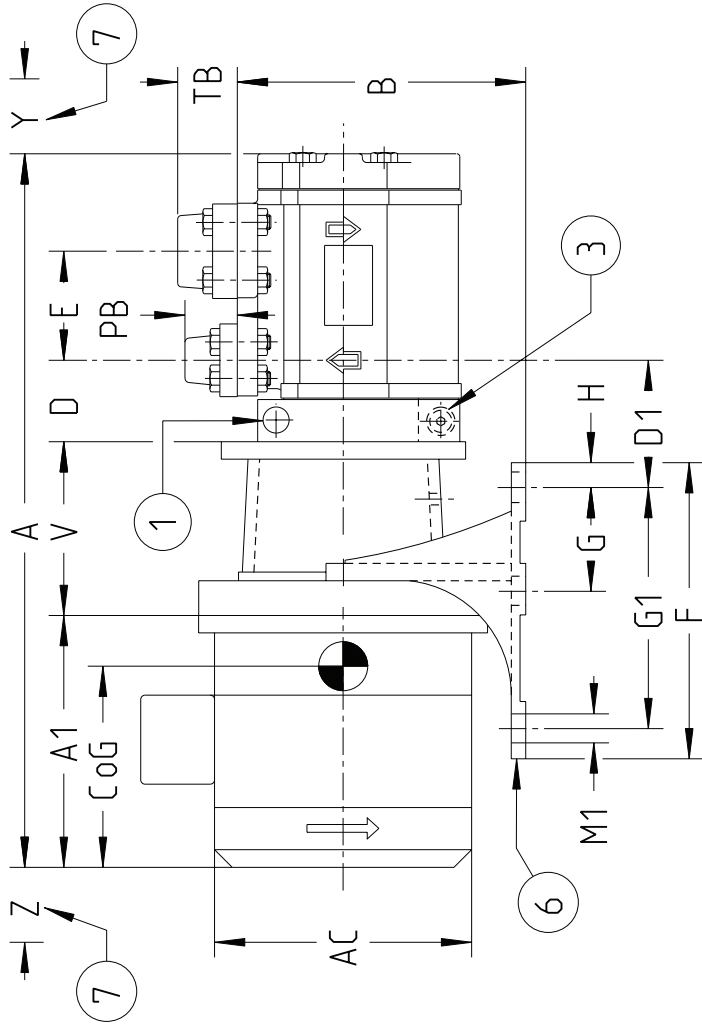

A-A

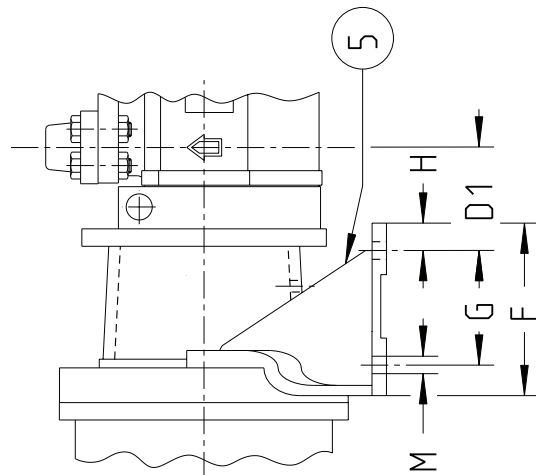
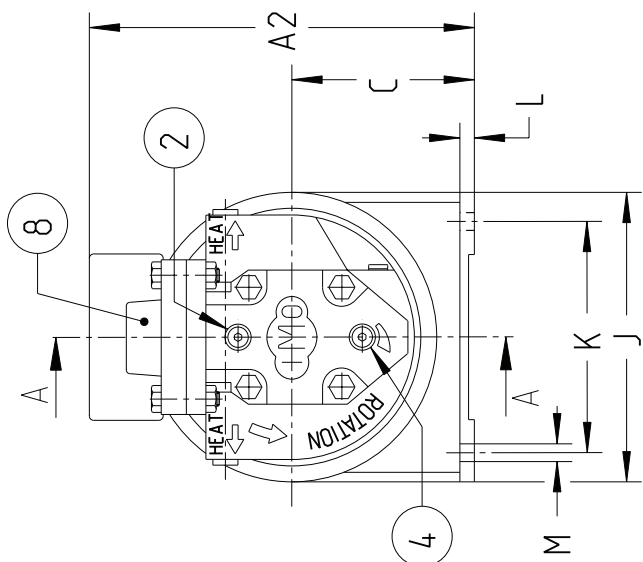

9. Pump Unit Dimensions

Pump size	IEC No	Frame size	Main dimensions										Foot dimensions										Outlet						Inlet			Dism.		Weight							
			A	A1	A2	AC	B	C	D	D1	E	V	F	G	G1	H	J	K	L	M	M1	P	PB	PR	PS	T	TB	R	S	Y	Z	CoG	kg								
025	80	F165	541	238	239	160	185	112	106	140	90	60	-	15	210	180	12	Ø11	-	25	37	27	30	133	293	27															
	90		575	272	247	178	155	46	60	175	230	75	185	22	250	215	15	14	24					170	293	33															
	100		646	308	309	199	228	155	142	140	90	60	-	15	210	180	12	Ø11	-	25	37	27	30	133	293	33															
	112		659	321	322	215	185	112	114	140	90	60	-	15	210	180	12	Ø11	-	25	37	27	30	133	293	33															
032	80	F165	577	238	239	160	185	112	114	140	90	60	-	15	210	180	12	Ø11	-	25	37	27	30	133	310	29															
	90		611	272	247	178	155	54	75	175	230	75	185	22	250	215	15	14	24					103	308	43															
	100		682	308	309	199	228	155	150	196	270	95	225	23	300	265	18	14	24					103	308	43															
	112		695	321	322	215	185	112	155	196	270	95	225	23	300	265	18	14	24					103	308	43															
038	132	F265	766	371	373	255	258	185	116	140	90	60	-	15	210	180	12	Ø11	-	40	42	42	49	133	325	32															
	80		583	238	239	160	195	112	116	140	90	60	-	15	210	180	12	Ø11	-	40	42	42	49	133	325	32															
	90		617	272	247	178	155	56	85	175	230	75	185	22	250	215	15	14	24					103	323	46															
	100		688	308	309	199	238	155	157	196	270	95	225	23	300	265	18	14	24					103	323	46															
038	112		701	321	322	215	185	157	157	196	270	95	225	23	300	265	18	14	24					113	319	51															
	132		772	371	373	255	268	185	157	196	270	95	225	23	300	265	18	14	24					113	321	75															

Drawing remarks:

- (1) Connection for heating. ISO G1/8
- (2) Inlet gauge. ISO G1/8
- (3) Other side: Outlet gauge. ISO G1/8
- (4) Relief valve. Turn clockwise to increase opening pressure

sure

- (5) Angle bracket for frame size F165
- (6) Angle bracket for frame size F215-F265
- (7) Space for dismantling
- (8) Butt weld counter flanges of IMO design necessary

Notes:

- Dimensions in mm
- Dimensions A, A1, AC, A2 and Weight are approximate values for Brook Crompton motors type WU-DA

10. Accessories

A bare shaft pump (Fig. 1) can be ordered with the accessories in fig. 2-8.

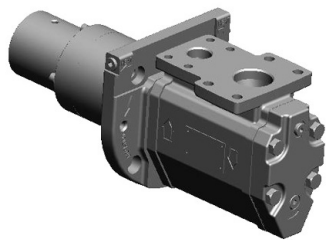

Fig. 1 Bare shaft pump

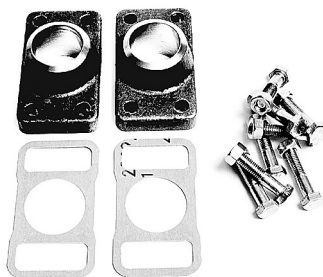

Fig. 2 Set of counter flanges

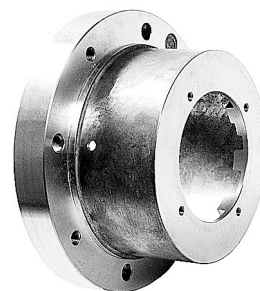

Fig. 3 Connecting frame

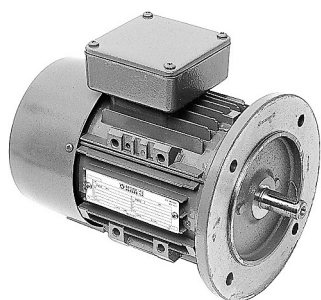

Fig. 4 Electric motor



Fig. 5 Angle Bracket

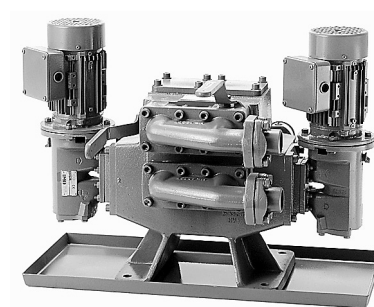

Fig. 6. Valve block



Fig. 7 Gauge panel

11. Maintenance

Spare parts for these pumps are easily available from stock. For detailed information and know-how about service, see the Service, Maintenance and Startup Instruction for ACE4 Opti-Line pumps or contact IMO AB.

**For latest updates, check:
www.imo.se**